



ALWAYS
THE BEST
**FLEXIBLE
SAFETY
BARRIERS**

FLEXIBLE PROTECTION



FLEXIBLE PROTECTION PRESENTS **NEW MATERIALS**

 **REFLEX**
RESISTANT AND FLEXIBLE

 **FROSTEX**
RESISTANT TO LOW TEMPERATURES

Issue No. FPS 5/23



CONTENTS

01	Rack Protection	page 08	10	Column Protection	page 70
02	Bollards	page 20	11	Access/Egress Protection	page 80
03	Guard Rails	page 26	12	Loading Dock Safety	page 86
04	Cold Line Protection System	page 32	13	Wheel Stop Barrier	page 90
05	Pedestrian Safety Barriers	page 40	14	Cable Cover	page 94
06	Pin	page 46	15	Corner Protection	page 96
07	Pedestrian Safety Gates	page 50	16	Kerb Protection	page 98
08	Link - Traffic Barrier	page 56	17	Wall Protection	page 102
09	BFlex - Safety Barrier System	page 64			



mpm

FLEXIBLE PROTECTIONS
WAREHOUSE



OUR MATERIALS



REFLEX

RESISTANT AND FLEXIBLE

FROSTEX

RESISTANT TO LOW TEMPERATURES

		
RESISTANT OVER TIME	HIGH ELASTICITY	COMPLIANT WITH THE DIRECTIVE UE 2015/863 (ROHS)
		
100% RECYCLABLE	SELF EXTINGUISHING V0	SCRATCHPROOF MATERIAL
		
HIGH VISIBILITY AND NO PAINTING REQUIRED	EASY TO CLEAN	ROT-PROOF AND NORMALLY MILDEW-PROOF MATERIAL
		
NON-TOXIC	RESISTANT TO CHEMICALS OIL AND FUELS	RESISTANT TO HUMIDITY AND SALINITY

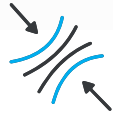
		
TEMPERATURE RANGE: -30° + 50° C	HIGH ELASTICITY	COMPLIANT WITH THE DIRECTIVE UE 2015/863 (ROHS)
		
100% RECYCLABLE	HB FLAMMABILITY RATING ACCORDING TO UL 94	SUITABLE FOR FOOD CONTACT
		
HIGH VISIBILITY AND NO PAINTING REQUIRED	RESISTANT TO CHEMICALS OIL AND FUELS	ROT-PROOF AND NORMALLY MILDEW-PROOF MATERIAL
		
NON-TOXIC	RESISTANT TO HUMIDITY AND SALINITY	

FIRE CERTIFICATION

OUR POLYMER CONFIRMS THE V0 SELF-EXTINGUISHING CLASS

MPM barriers are classified V0, according to international UL94 standard. The protections in Reflex technopolymer:

- Are low fire risk;
- Are self-extinguishing;
- Don't spread the flame and stop burning within few seconds.

The installation of our barriers lowers fire risk, in order to measure the size of the fire extinguishing system, compared to other barriers made of alternative polymers – not classified as V0.

Le barriere MPM sono classificate V0, secondo lo standard internazionale UL94. Le protezioni in tecnopolimero Reflex:

- Hanno un basso carico d'incendio;
- Sono autoestinguenti;
- Non propagano la fiamma e smettono di bruciare entro pochi secondi.

L'installazione delle nostre barriere riduce il carico d'incendio utilizzato ai fini del calcolo del dimensionamento del sistema antincendio, rispetto ad altre barriere in polimeri alternativi - non classificati V0.

Les barrières MPM sont classées V0, selon la norme internationale UL94. Les protecteurs en technopolymère Reflex:

- Ils ont une faible charge d'incendie;
- Ils sont auto-extinguibles;
- Ils ne propagent pas la flamme et cessent de brûler en quelques secondes.

La présence de nos barrières réduit la charge d'incendie utilisée pour le calcul du dimensionnement du système d'extinction d'incendie, par rapport à d'autres barrières en polymères alternatifs - non classées V0.

Las barreras MPM están clasificadas como V0, según la norma internacional UL94. Las protecciones de tecnopolímero Reflex:

- Tienen una baja carga de fuego;
- Son autoextinguibles;
- No propagan la llama y dejan de arder en unos segundos.

La instalación de nuestras barreras reduce la carga de fuego utilizada para el cálculo del dimensionamiento del sistema de protección contra incendios, en comparación con otras barreras de polímero alternativas, no clasificadas como V0.



REFLEX
RESISTANT AND FLEXIBLE

IS FIRE RESISTANT
CLASS V-0

AVAILABLE FOR:
LM / PED 150 /
TOWER

RESEARCH AND DEVELOPMENT NEVER STOP!

ORANGE LINE



HIGHER
VISIBILITY
FOR A GREATER
SAFETY!

CLIP 90



CUSTOMIZE
YOUR BARRIER

EASY TO
INSTALL

MORE
VISIBILITY

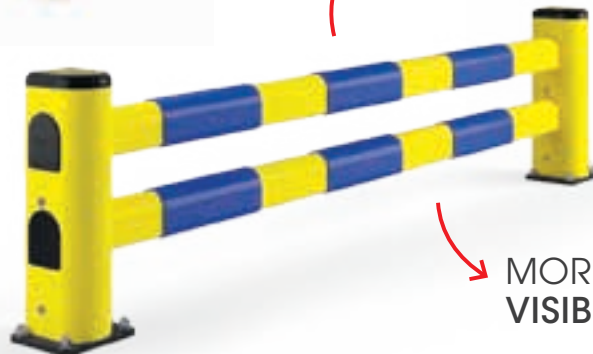

CUT THE RAIL AND DRILL IT WITH

GENIUS

THE LENGTH THAT YOU WISH

FOR MINI HUG TOWER



FOR HUG TOWER



FOR PEDESTRIAN BARRIER CORNER RAILS



FOR PEDESTRIAN BARRIER RAILS

WORLD'S UNIQUE SYSTEM!

YOUR CUSTOMIZED BARRIER AND HUG TOWER



01

RACK PROTECTION OUR PROFILES FIT ALL RACKS

Full range of techno polymer profiles for protection of warehouse racks.

Gamma completa di profili in tecnopolimeri per la protezioni di scaffali.

Complète gamme de profilés en tecnopolimère pour la protection d'étagères de dépôts.

Gama completa de perfiles de tecnopolímeros para las protecciones de estanterías.

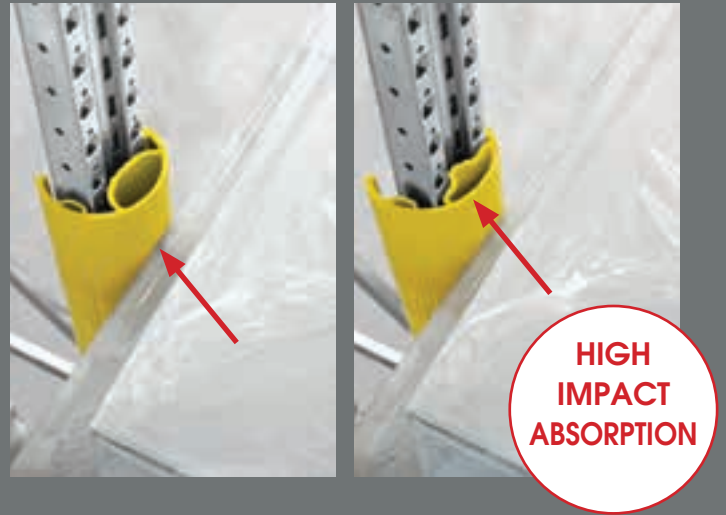

- ▶ **One big central shock absorber** in soft material to absorb front impacts.
- ▶ **Two side shock absorbers** in soft material to absorb impact during pallet placement on the rack.
- ▶ **Tested and certified** to EN 15512
- ▶ **Reduced dimensions** to keep manoeuvring spaces clear.
- ▶ **Interlocking system** with practical click-fit tools.
- ▶ **Rigid outer cladding, scratch-resistant** and easy to clean.



RPS / RPM / RPL

EASY TO INSTALL

THE ONLY ONE WITH TRIPLE SHOCK ABSORBER

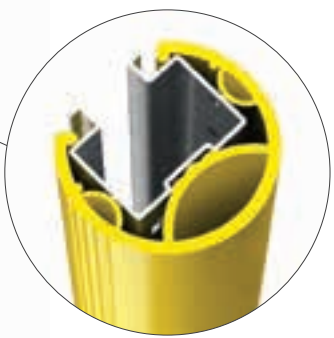

CUSTOMIZED SOLUTIONS TO FIT ALL UPRIGHTS



RPS 600



Small

Available also size 400

Packing 6 pz / box
Packing 115 pz / big parcel
Colour **M**



RPM 600



Medium

Available also size 400

Packing 4 pz / box
Packing 80 pz / big parcel
Colour **M**



RPL 600



Large

Available also size 400

Packing 2 pz / box
Packing 52 pz / big parcel
Colour **M**



RPL XL 600



Extra Large

Available also size 400

Packing to be defined
Colour **M**



RP CLICK

Packing 2 pz / box

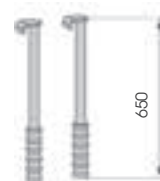

RACK CORNER

ANTISHOCK
MATERIAL
INSIDE

FAST
AND EASY
TO INSTALL

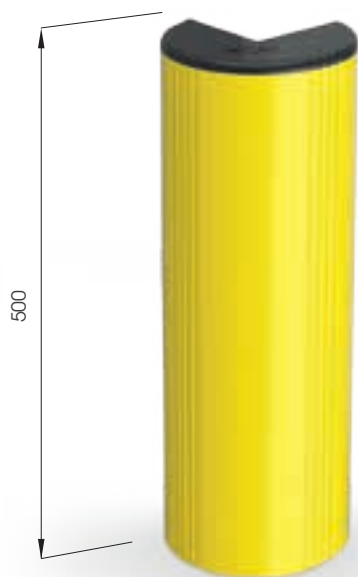

RACK CORNER

Packing Colour **to be defined**
M

Equipped with accessories

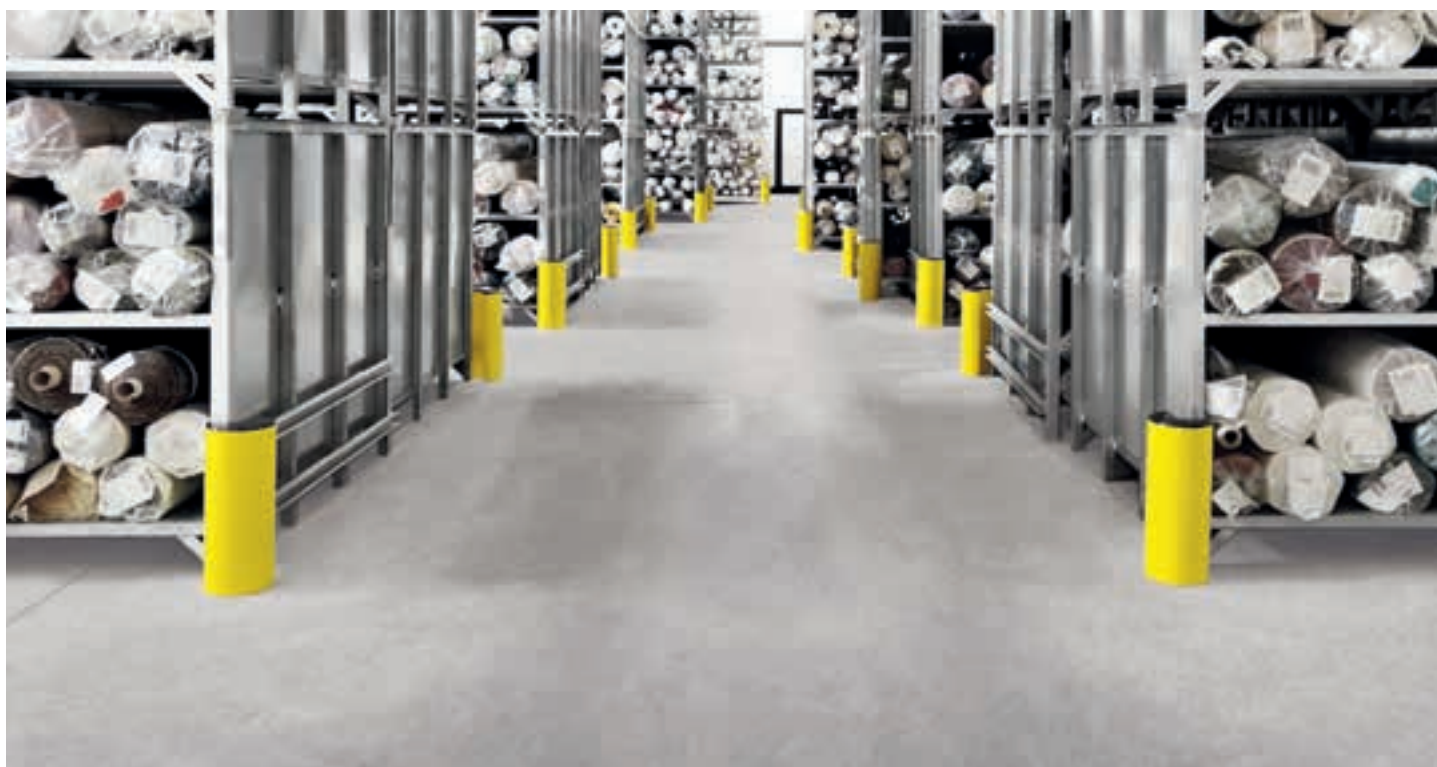
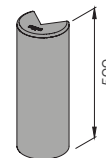

SM



DIFFERENT
SIZES ON
REQUEST

FAST
AND EASY
TO INSTALL

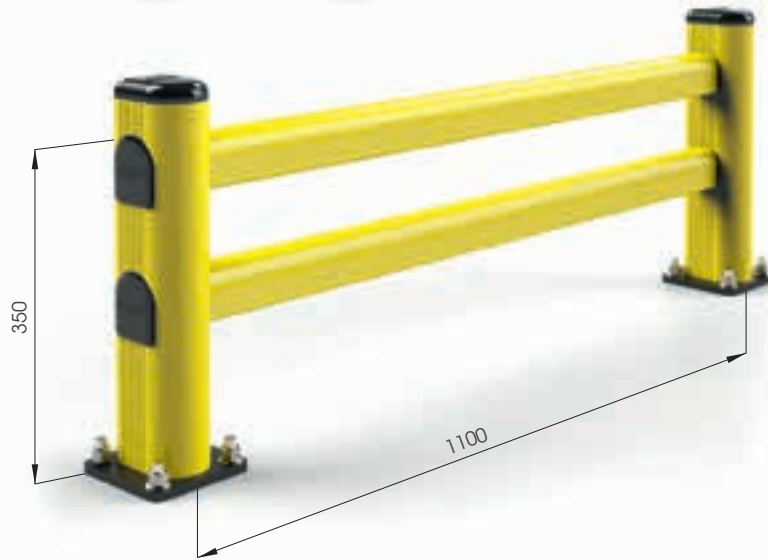

M12
GALVANISED STEEL



SM 1100x400

Length **1.100**
Packing **unpacked on pallet**
Colour **B M**

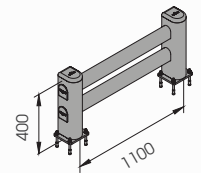

Equipped with accessories



SM 1500x400 MODULAR

Packing **unpacked on pallet**
Colour **B M**

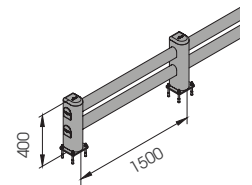

Equipped with accessories



Rack end Barriers

LM



DIFFERENT SIZES ON REQUEST

FAST AND EASY TO INSTALL

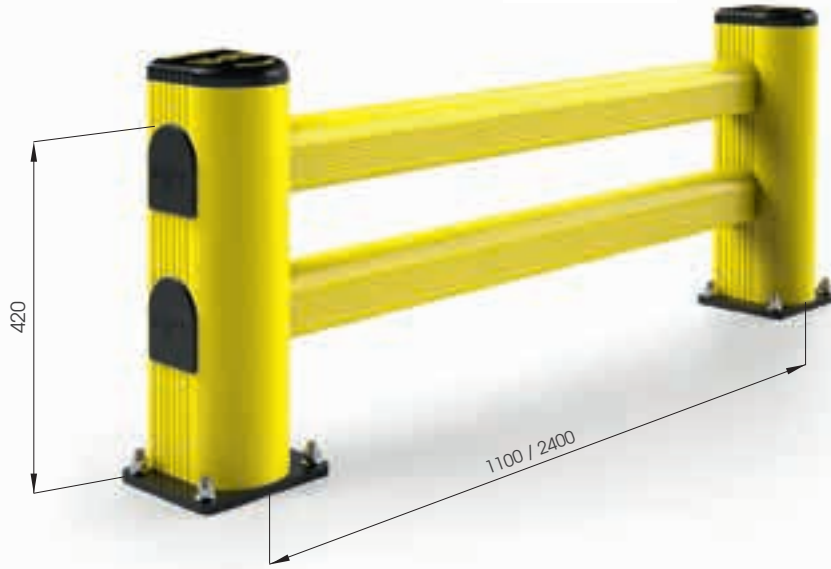

M12 GALVANISED STEEL



LM RACK END 1100x500
2400x500

Length 1.100 / 2.400 mm
Packing unpacked on pallet
Colour B M

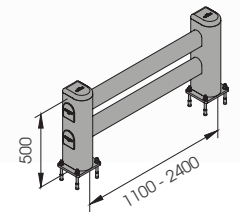

Equipped with accessories



LM 2000x500 MODULAR

Packing unpacked on pallet
Colour B M

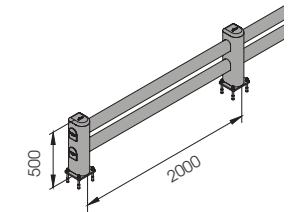

Equipped with accessories



LM/1 LINK



DIFFERENT SIZES ON REQUEST



M12 GALVANISED STEEL



**LM/1 LINK RACK END
1100x500
2400x500**

Length **1.100 / 2.400 mm**
Packing **unpacked on pallet**
Colour **B M**

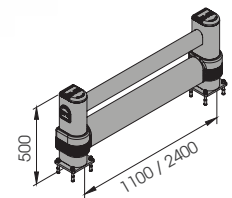

Equipped with accessories

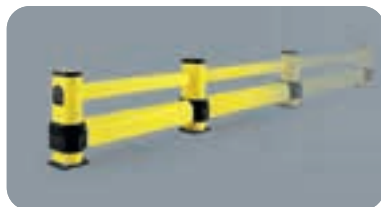

**LM / 1 LINK 2000x500
MODULAR**

Packing **unpacked on pallet**
Colour **B M**

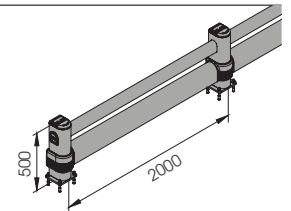

Equipped with accessories



LINK SINGLE



DIFFERENT SIZES ON REQUEST

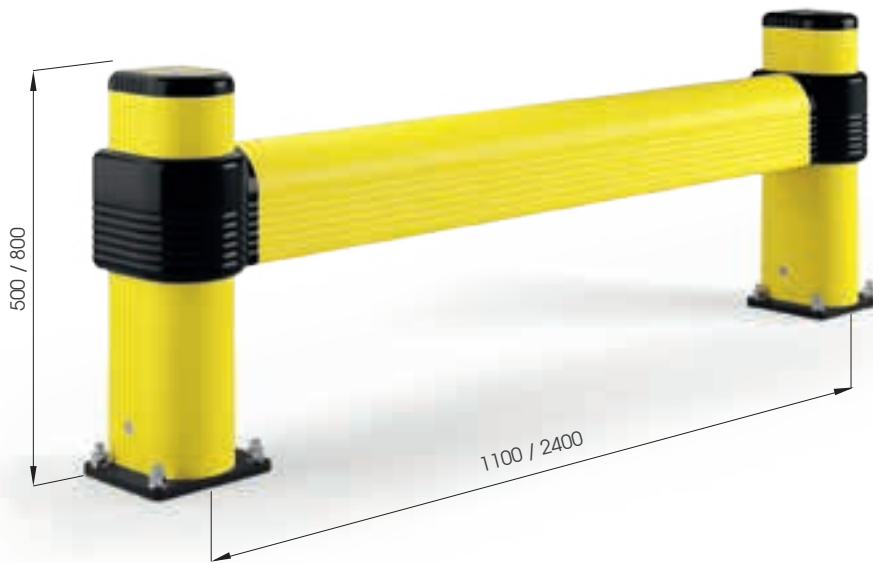

LINK SINGLE RACK END
 1100x500
 1100x800
 2400x500
 2400x800

Length 1.100 / 2.400 mm
 Packing unpacked on pallet
 Colour **B** **M**

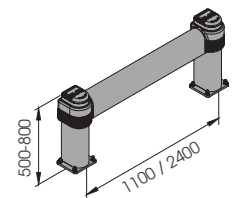

Equipped with accessories

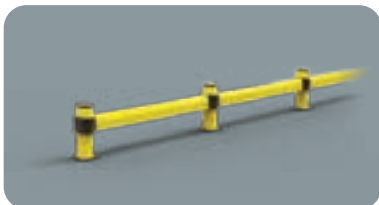

LINK SINGLE 2000x500 MODULAR
LINK SINGLE 2000x800 MODULAR

Packing unpacked on pallet
 Colour **B** **M**

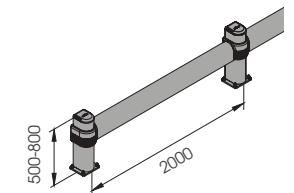

Equipped with accessories

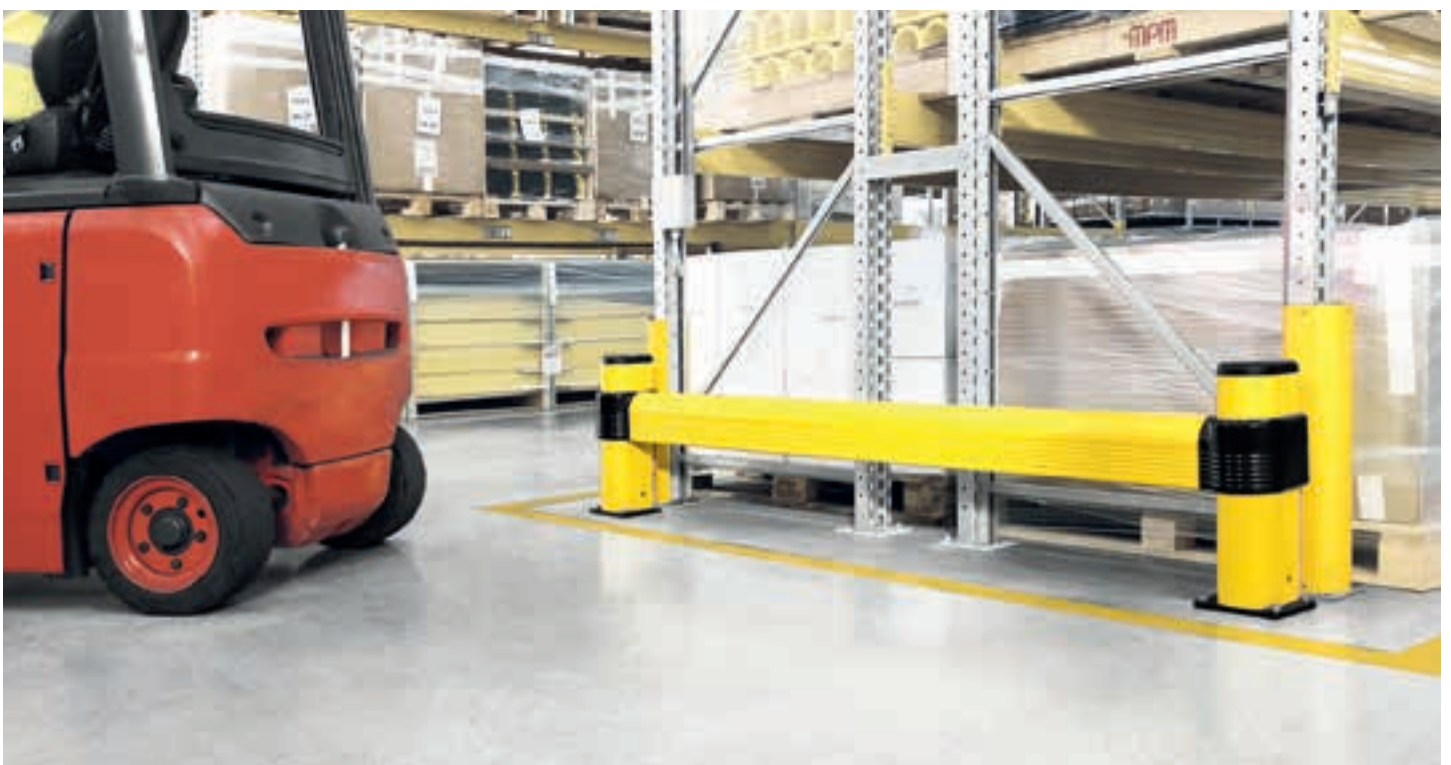

LINK LM



DIFFERENT SIZES ON REQUEST



M12 GALVANISED STEEL



LINK LM RACK END
 1100x500
 1100x800
 2400x500
 2400x800

Equipped with accessories

Length 1.100 / 2.400 mm
 Packing unpacked on pallet
 Colour **B** **M**

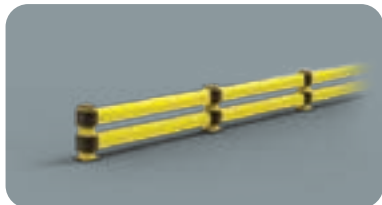
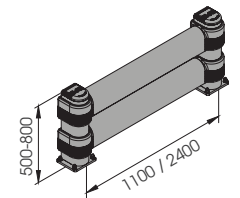

LINK LM 2000x500 MODULAR
LINK LM 2000x800 MODULAR

Equipped with accessories

Packing unpacked on pallet
 Colour **B** **M**

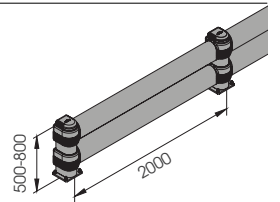

Rack end Barriers

FENCE 90



DIFFERENT SIZES ON REQUEST

FAST AND EASY TO INSTALL



M12 GALVANISED STEEL



FE 90 1100x400

Length **1.100 mm**
Packing **unpacked on pallet**
Colour **B M**

Equipped with accessories



FE 90 2400x400

Length **2.400 mm**
Packing **unpacked on pallet**
Colour **B M**

Equipped with accessories



FENCE 150



DIFFERENT SIZES ON REQUEST

FAST AND EASY TO INSTALL



M12 GALVANISED STEEL



FE 150 1100x550

Length **1.100 mm**
Packing **unpacked on pallet**
Colour **B M**

Equipped with accessories



FE 150 2400x550

Length **2.400 mm**
Packing **unpacked on pallet**
Colour **B M**

Equipped with accessories



FENCE 150 REINFORCED



DIFFERENT SIZES ON REQUEST

FAST AND EASY TO INSTALL



FE 150 REF 1100x550

Length **1.100 mm**
 Packing **unpacked on pallet**
 Colour **B M**

Equipped with accessories



FE 150 REF 2400x550

Length **2.400 mm**
 Packing **unpacked on pallet**
 Colour **B M**

Equipped with accessories



FENCE LINK



DIFFERENT SIZES ON REQUEST

FAST AND EASY TO INSTALL



FE LINK 1100x550

Length **1.100 mm**
 Packing **unpacked on pallet**
 Colour **B M**

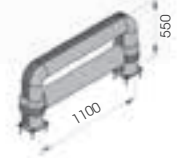

Equipped with accessories



FE LINK 2400x550

Length **2.400 mm**
 Packing **unpacked on pallet**
 Colour **B M**

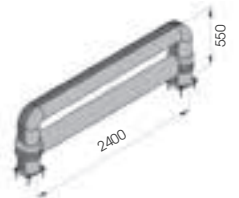

Equipped with accessories



02

BOLLARDS

Designed to protect access to gates or big doors from huge traffic or simply to mark restricted areas for pedestrians.
Fully equipped with fixing accessories.

Ideato per proteggere l'accesso a cancelli o portoni dalla movimentazione di mezzi pesanti o semplicemente per impedire l'ingresso di pedoni. Provvisto di accessori di fissaggio.

Étudié pour protéger l'accès aux portes ou entrées de grand trafic ou simplement pour marquer les zones de passage piétons. Equipé avec les accessoires d'installation.

Diseñado para proteger el acceso a puertas o portones del movimiento de vehículos pesados o simplemente para evitar la entrada de peatones. Provisto de accesorios de fijación.



GRD 90



FAST AND EASY TO INSTALL



M12 GALVANISED STEEL



GRD 90 250

Packing Colour **unpacked on pallet**



Equipped with accessories



Bollards

GRD 150



FAST
AND EASY
TO INSTALL



M12
GALVANISED STEEL



GRD 150 500
800
1150

Packing Colour **unpacked on pallet**
B M

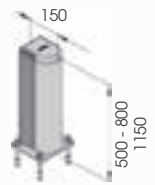

Equipped with accessories



GRD 200

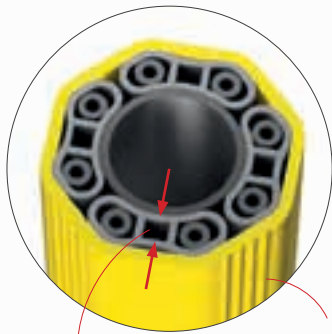

FLEXIBLE

NEW ANTISHOCK BUMPER



INCLUDED

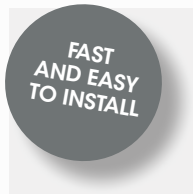

S16 GALVANISED STEEL



GRD 200 1200 2000

Packing Colour **unpacked on pallet**



Equipped with accessories



VISIPOLE

SIGN OPTIONS

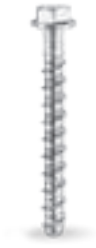

**S12
GALVANISED STEEL**



VISIBOARD

Sign to be defined
Packing to be defined

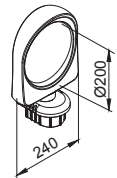

VISIPOLE

Packing to be defined

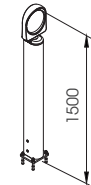

Equipped with accessories



SOFT BOLLARD



SOFT BOLLARD

Packing to be defined

Equipped with accessories

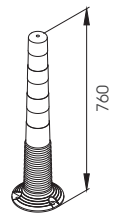

03

GUARD RAILS

A new bumper system specific for the protection of the walls resistant against trolleys movements. Developed by following an innovative technical design that combines speed and simplicity during installation and cleaning. Available in different lengths.

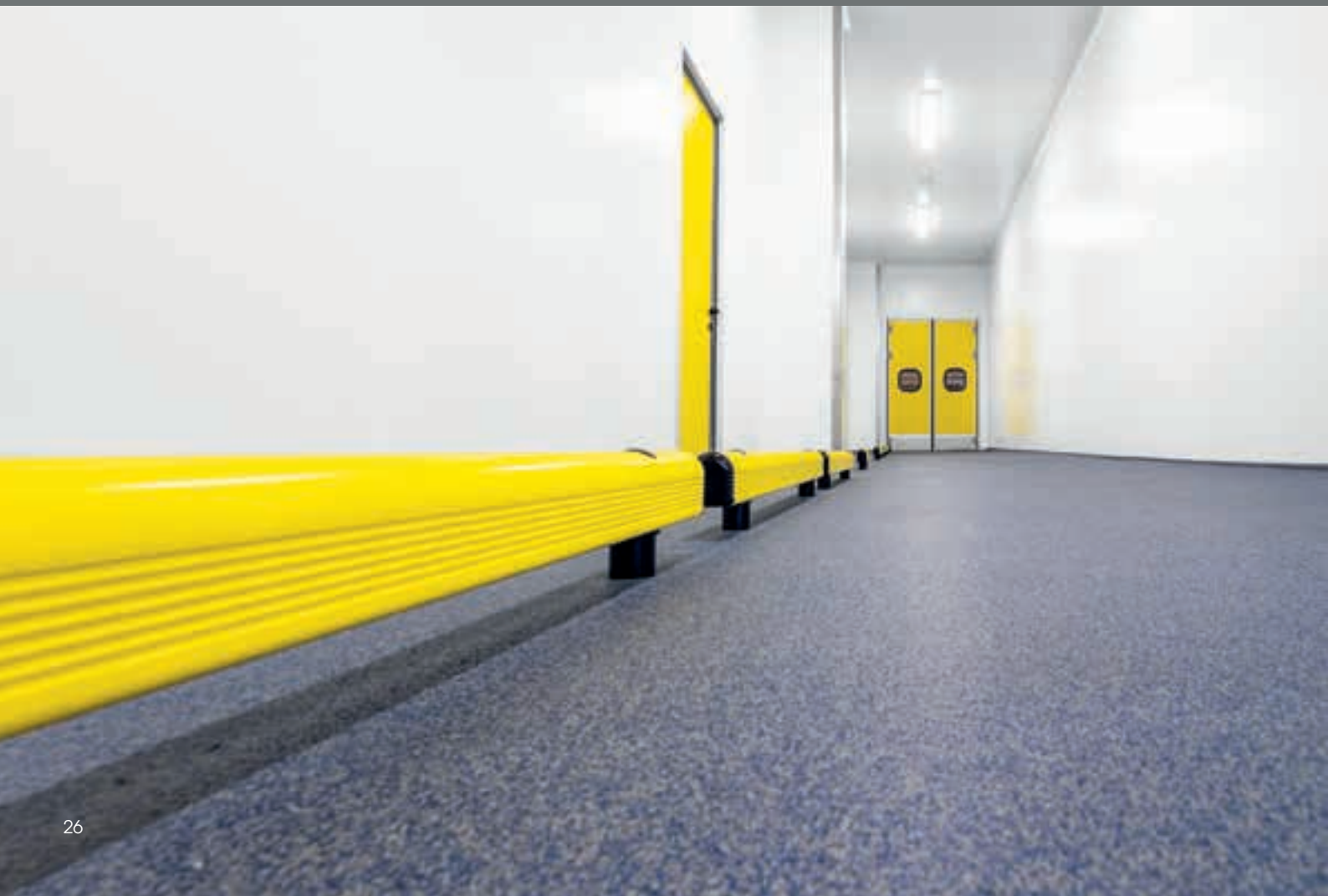

Sistema profili antiurto specifico per la protezione delle pareti dai carrelli in movimento. Progettato seguendo un innovativo disegno tecnico che coniuga rapidità e semplicità nelle fasi di installazione e pulizia. Disponibile in diverse lunghezze.

Nouveau système bumper, spécifique pour protéger les murs contre les mouvements des charriots. Étudié avec un modern dessin qui regroupe la rapidité et la facilité pendant l'installation et le nettoyage. Disponible en différents longueurs.

Sistema de perfiles anti-impacto específico para la protección de las paredes de los carros en movimiento. Diseñado según un diseño técnico innovador que une velocidad y simplicidad en las fases de instalación y limpieza. Disponible en diferentes longitudes.



Guard Rails

GUARD RAIL 90



**QUICK
INSTALLATION
WITH
EXPANSION
SCREW**



**M16
GALVANISED STEEL**



ALTERNATIVE FIXING
HIGH RESISTANCE WITH RESIN



**SF16
STAINLESS STEEL**



GR 90 500
750
1000
1500

Length **500 mm**
Packing **unpacked on pallet**

Length **750 / 1000 / 1500 mm**
Packing **2 pz / box**

Colour **B M**

Equipped with accessories

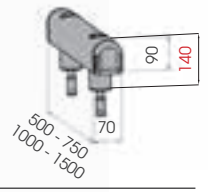

GR 90 2000
3000
4000

Length **2.000 / 3.000 / 4.000 mm**
Packing **unpacked on pallet**

Colour **B M**

Equipped with accessories

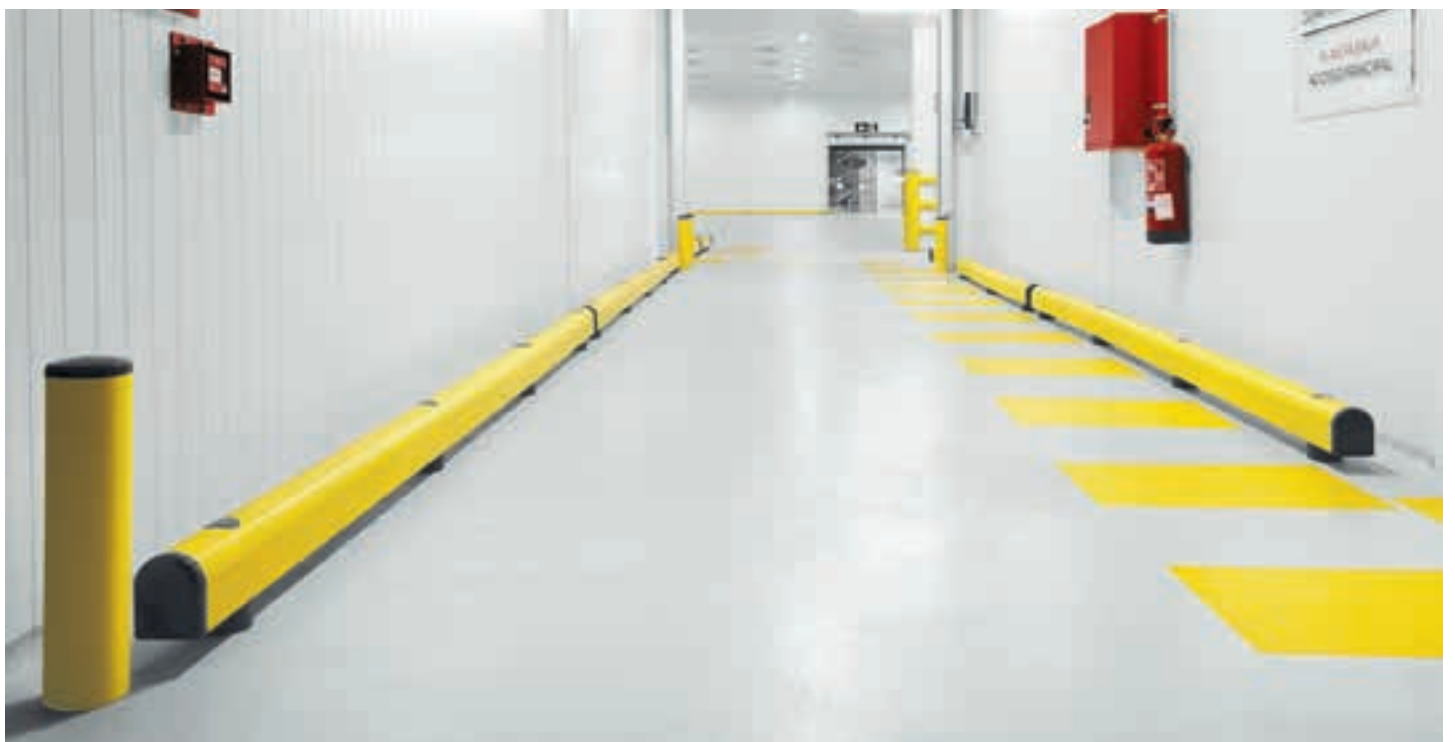
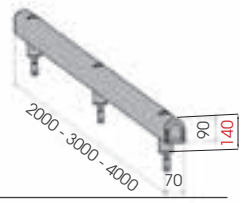

GUARD RAIL 150



HIGH RESISTANCE WITH RESIN

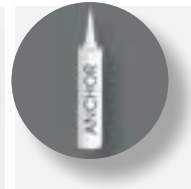

SF20 STAINLESS STEEL



GR 150 500
750
1000
1500

Length **500 / 750 / 1000 / 1500 mm**
Packing **unpacked on pallet**
Colour **B M**

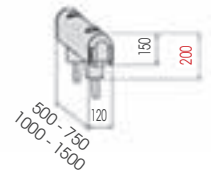

Equipped with accessories



GR 150 2000
3000
4000

Length **2.000 / 3.000 / 4.000 mm**
Packing **unpacked on pallet**
Colour **B M**

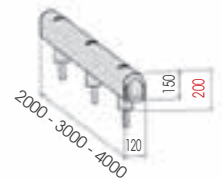

Equipped with accessories



Guard Rails

GRIN 90

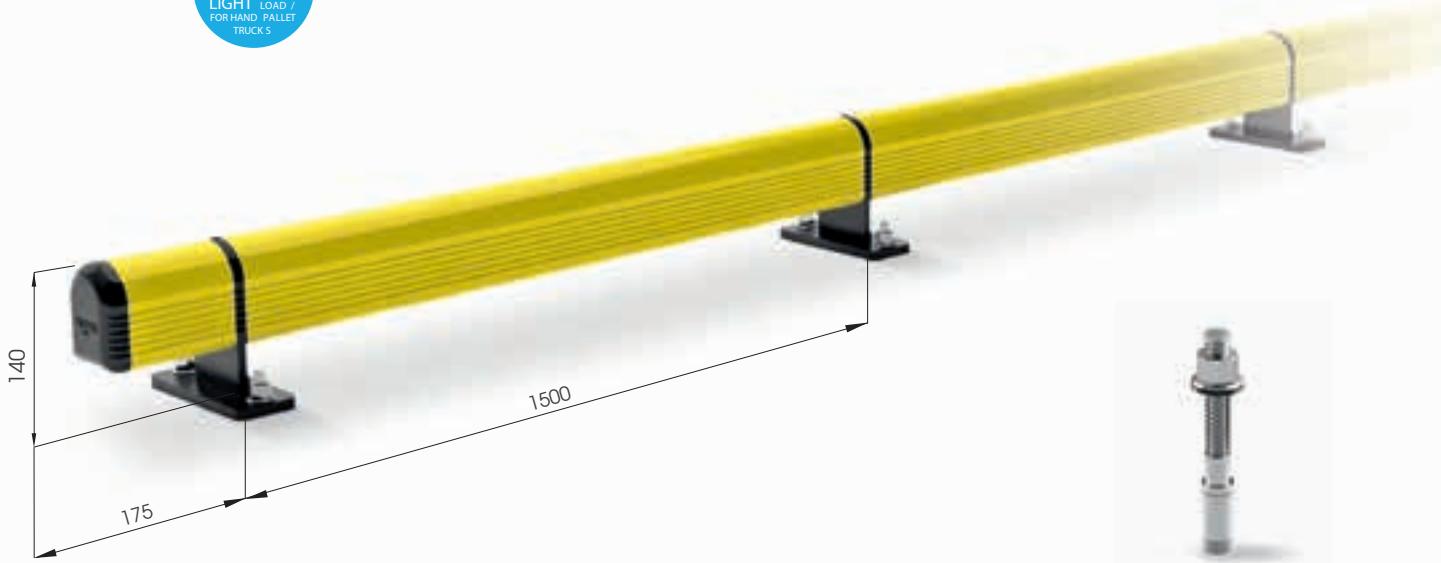

GRIN 90 1500

Length **1500 mm**
Packing **to be defined**
Colour **M**



GRINCO 90

Packing **to be defined**
Colour **M**



Equipped with accessories



GRINT 90

Packing **to be defined**
Colour **M**



Equipped with accessories



GRIN 150



**M12
GALVANISED STEEL**



GRIN 150 2000

Length **2000 mm**
Packing **to be defined**
Colour **M**



GRINCO 150

Packing **to be defined**
Colour **M**



Equipped with accessories



GRINT 150

Packing **to be defined**
Colour **M**



Equipped with accessories



04

COLD LINE PROTECTION SYSTEM

Specific solutions for the protection of areas at risk of impact, in environments with negative temperature. They are suitable to protect corners, entrances, gates, panels and cold rooms walls.

Soluzioni specifiche per la protezione di zone a rischio d'impatto in ambienti a temperatura negativa. Ideali per proteggere angoli sporgenti, accessi e portoni, pannelli e pareti di celle frigorifere.

Solutions spécifiques pour la protection des zones à risque de collision dans les environnements à température négative. Idéal pour protéger les angles, les entrées et les portes, les panneaux et les murs des chambres froides.

Soluciones específicas para proteger las zonas con riesgo de impacto en entornos de temperatura negativa. Son ideales para proteger esquinas, entradas y puertas, paneles y paredes de las cámaras frigoríficas.



FROSTEX
RESISTANT TO LOW TEMPERATURES

-30° RESISTANT TO LOW TEMPERATURES



ROD 70

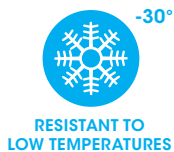

Fixing accessory available also in stainless steel



ROD 70 266

Packing Colour **1 pz / box**
M

Drill Ø 38
 Equipped with accessories

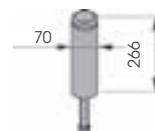

Cold Line Protection System

ROD 120

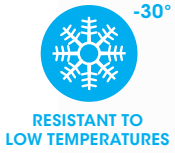

Fixing accessory available also in stainless steel



**ROD 120 433
560
800**

Drill Ø 56
Equipped with accessories

Packing Colour **1 pz / bag**
M

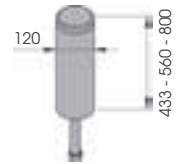

FLOOR ROD 70



**QUICK
INSTALLATION
WITH
EXPANSION
SCREW**



**M16
GALVANISED STEEL**

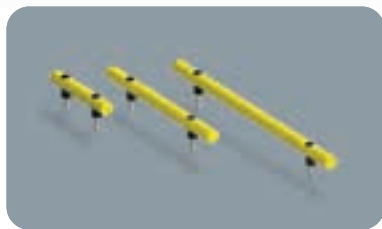
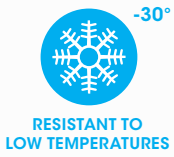

RF 70 500
1000
1500

Length **500 / 1000 / 1500 mm**
Packing **unpacked on pallet**
Colour **M**

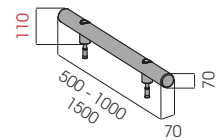

Equipped with accessories



RF 70 2000
3000

Length **2.000 / 3.000 mm**
Packing **unpacked on pallet**
Colour **M**

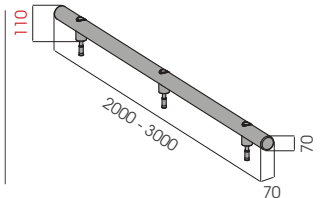

Equipped with accessories



Cold Line Protection System

FLOOR ROD 100



HIGH RESISTANCE WITH RESIN

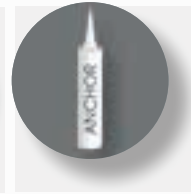

SF20 STAINLESS STEEL

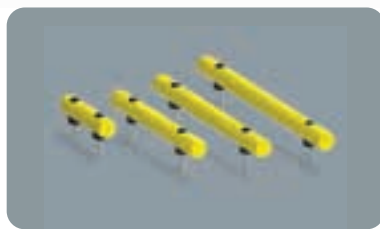
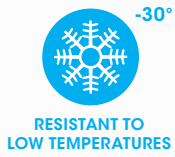

RF 100 500
1000
1500

Length 500 / 1000 / 1500 mm
Packing unpacked on pallet
Colour **M**

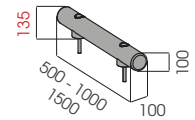

Equipped with accessories



RF 100 2000
3000

Length 2.000 / 3.000 mm
Packing unpacked on pallet
Colour **M**

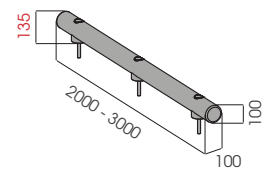

Equipped with accessories



FLOOR ROD 120



HIGH RESISTANCE WITH RESIN

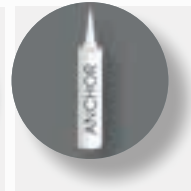

SF20 STAINLESS STEEL



-30°
RESISTANT TO LOW TEMPERATURES



**RF 120 500
1000
1100
1500**

Length **500 / 1000 / 1100 / 1500 mm**
Packing **unpacked on pallet**
Colour **M**

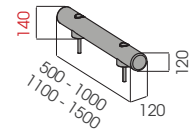

Equipped with accessories

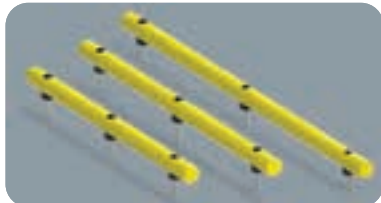

**RF 120 2000
2500
3000**

Length **2.000 / 2.500 / 3.000 mm**
Packing **unpacked on pallet**
Colour **M**

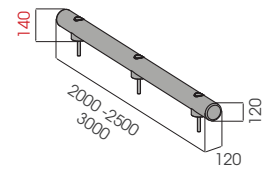

Equipped with accessories

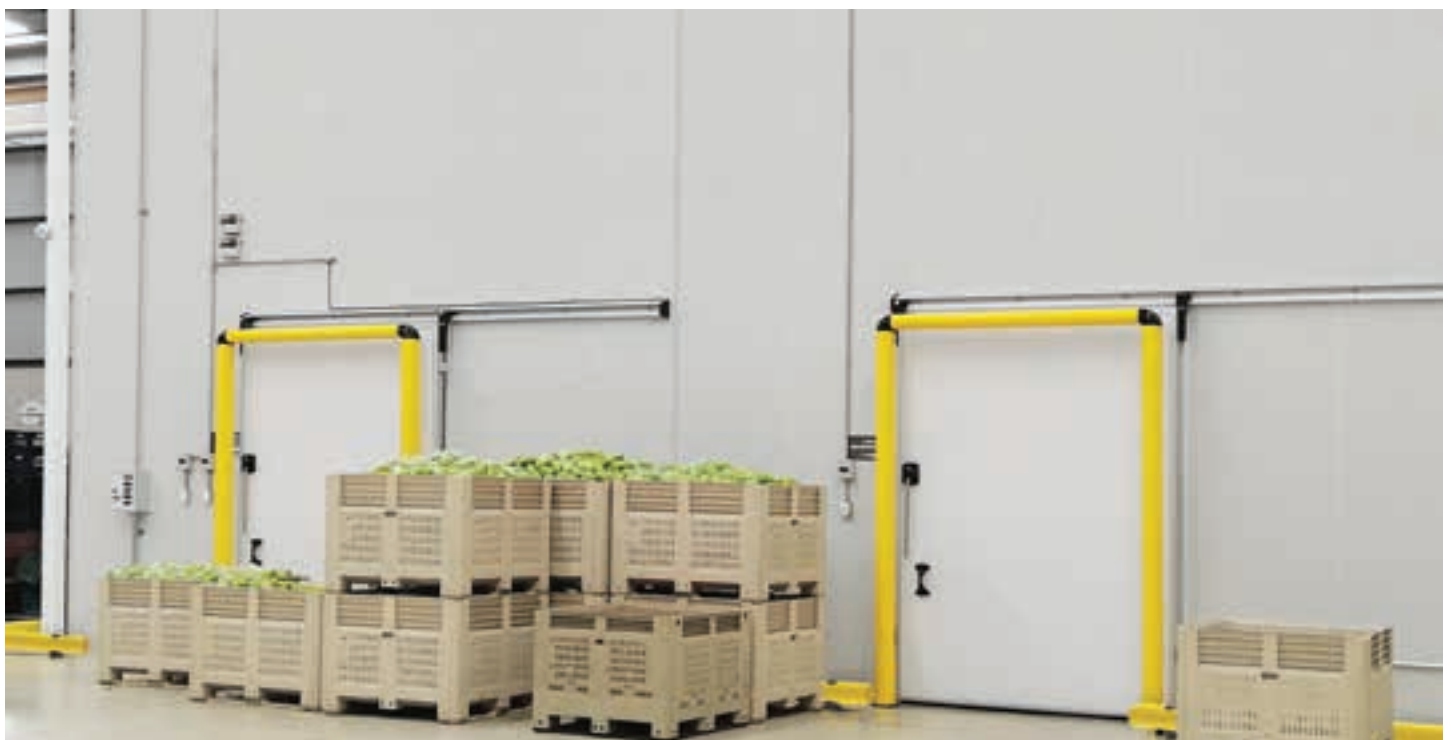

FLOOR ROD 120 DOUBLE RACK END



SF20 x 450
STAINLESS STEEL

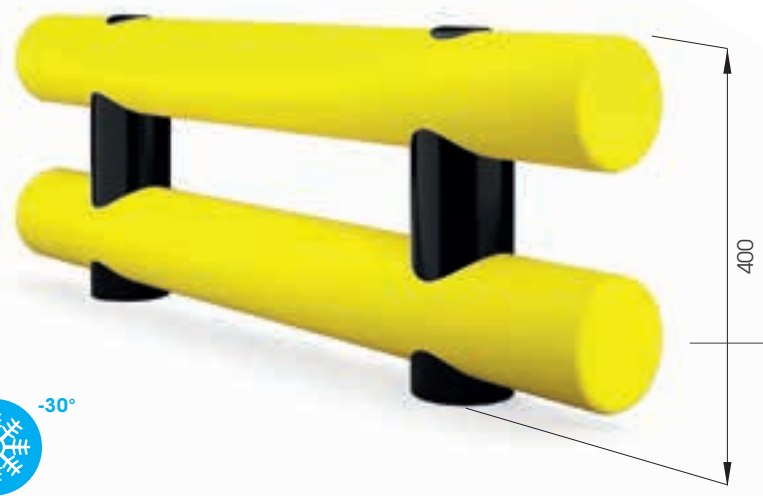

NO SHARP EDGES

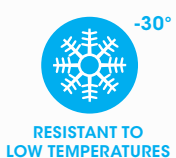

RF 120 DOUBLE RACK END 1100

Length **1100 mm**
Packing **unpacked on pallet**
Colour **M**

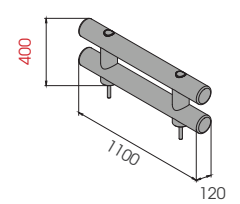

Equipped with accessories



RF 120 DOUBLE RACK END 2500

Length **2.500 mm**
Packing **unpacked on pallet**
Colour **M**

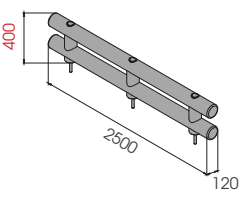

Equipped with accessories



FLOOR ROD 120 DOUBLE

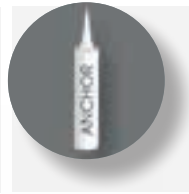

SF20 x 450
STAINLESS STEEL

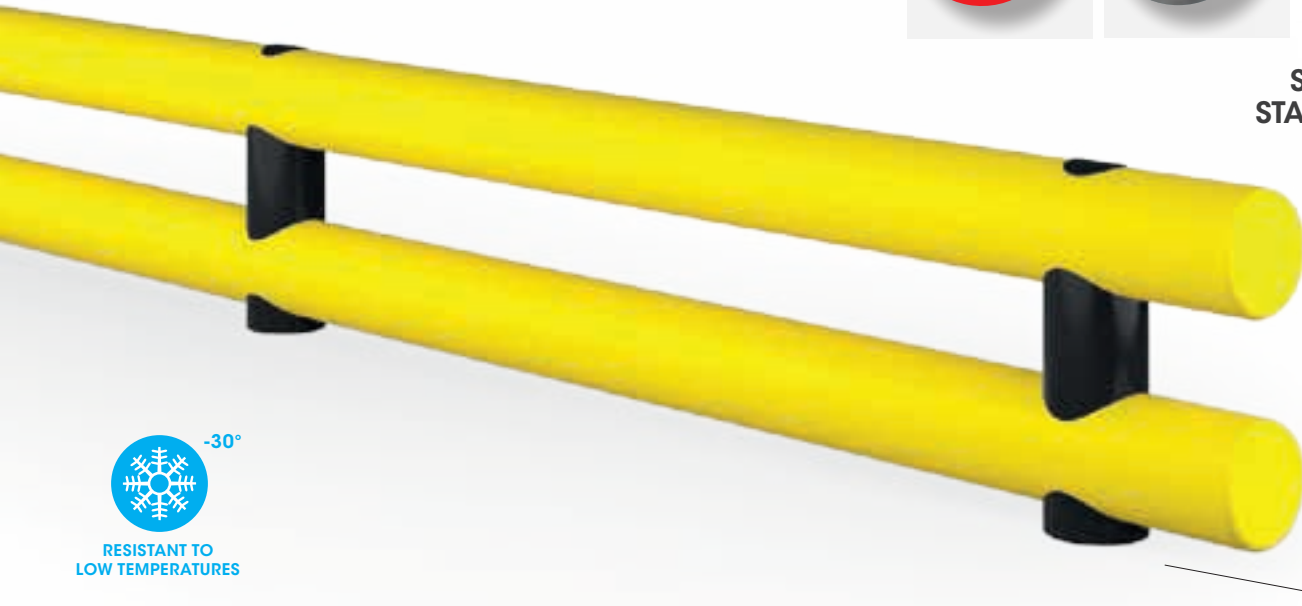

400

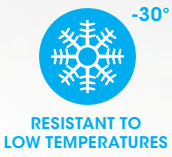

RESISTANT TO
LOW TEMPERATURES

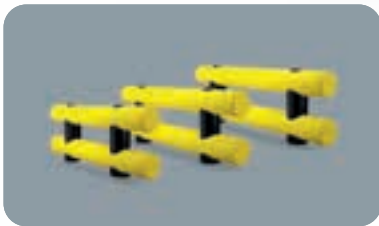

RF 120 DOUBLE 500
1000
1500

Length 500 / 1000 / 1500 mm
Packing unpacked on pallet
Colour M

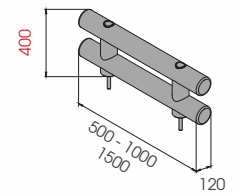

Equipped with accessories

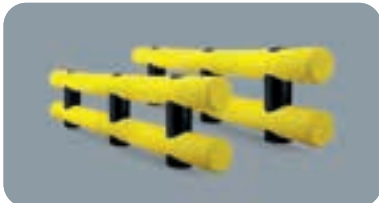

RF 120 DOUBLE 2000
3000

Length 2.000 / 3.000 mm
Packing unpacked on pallet
Colour M

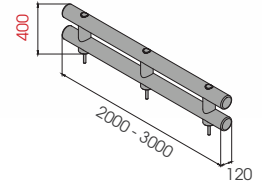

Equipped with accessories



05

PEDESTRIAN SAFETY BARRIERS

A new protection system specific for the protection of pedestrians and resistant to trolleys movements with different load types. Developed by following an innovative technical design that combines speed and simplicity during installation and cleaning. Available in different lengths.

Sistema di profili antiurto specifico per la protezione delle aree pedonali dai carrelli in movimento con diverse portate di carico. Progettato seguendo un innovativo disegno tecnico che coniuga rapidità e semplicità nelle fasi di installazione e pulizia. Disponibile in diverse lunghezze.

Nouveau système bumper, spécifique pour protéger les zones piétonnes contre les mouvements des charriots. Étudié avec un modern dessin qui regroupe la rapidité et la facilité pendant l'installation et le nettoyage. Disponible en différents longueurs.

Sistema específico de perfiles antichoque para la protección de zonas peatonales de carros en movimiento con diferentes capacidades de carga. Diseñado según un diseño técnico innovador que une velocidad y simplicidad en las fases de instalación y limpieza. Disponible en diferentes longitudes.



HAND RAIL 90



FAST AND EASY TO INSTALL

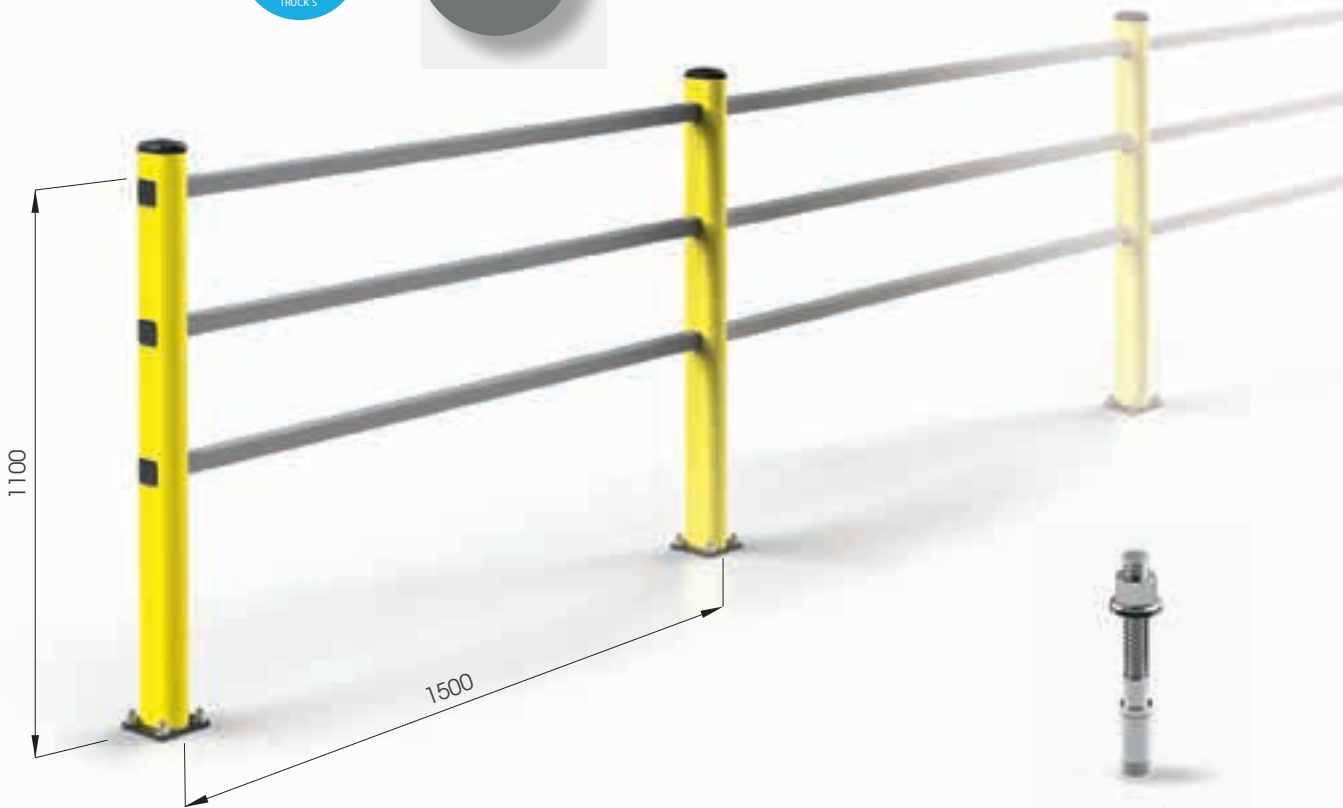

M12 GALVANISED STEEL

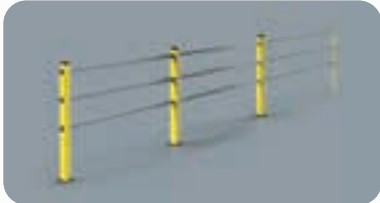

HR 90 1500x1150 MODULAR

Packing Colour **unpacked on pallet**
Colour **M**



Equipped with accessories

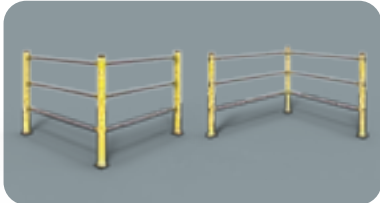

HR 90 1500x1150 CORNER

Packing Colour **unpacked on pallet**
Colour **M**

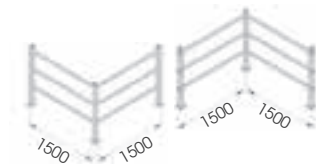

Equipped with accessories



PEDESTRIAN 90



FAST AND EASY TO INSTALL



M12 GALVANISED STEEL

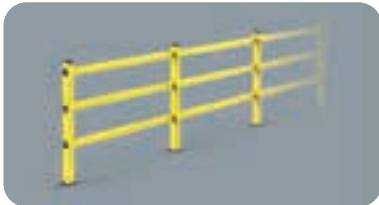

PED 90 1500x1150 MODULAR

Packing Colour **unpacked on pallet**
 B M

Equipped with accessories



PED 90 1500x1150 CORNER

Packing Colour **unpacked on pallet**
 B M

Equipped with accessories

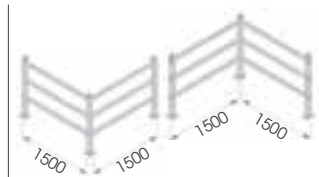

PEDESTRIAN 150



FAST AND EASY TO INSTALL

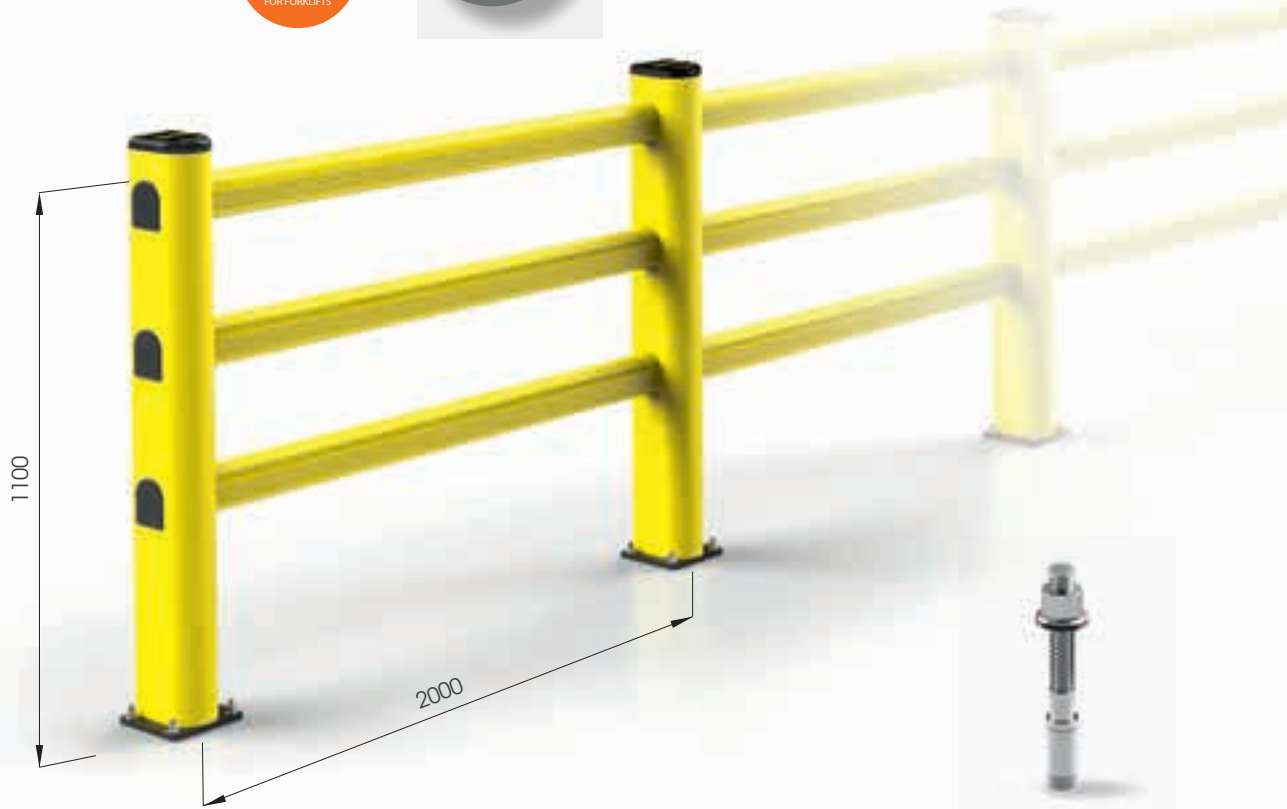

M12 GALVANISED STEEL



PED 150 2000x1150 MODULAR

Packing Colour **unpacked on pallet**
B M

Equipped with accessories



PED 150 2000x1150 CORNER

Packing Colour **unpacked on pallet**
B M

Equipped with accessories

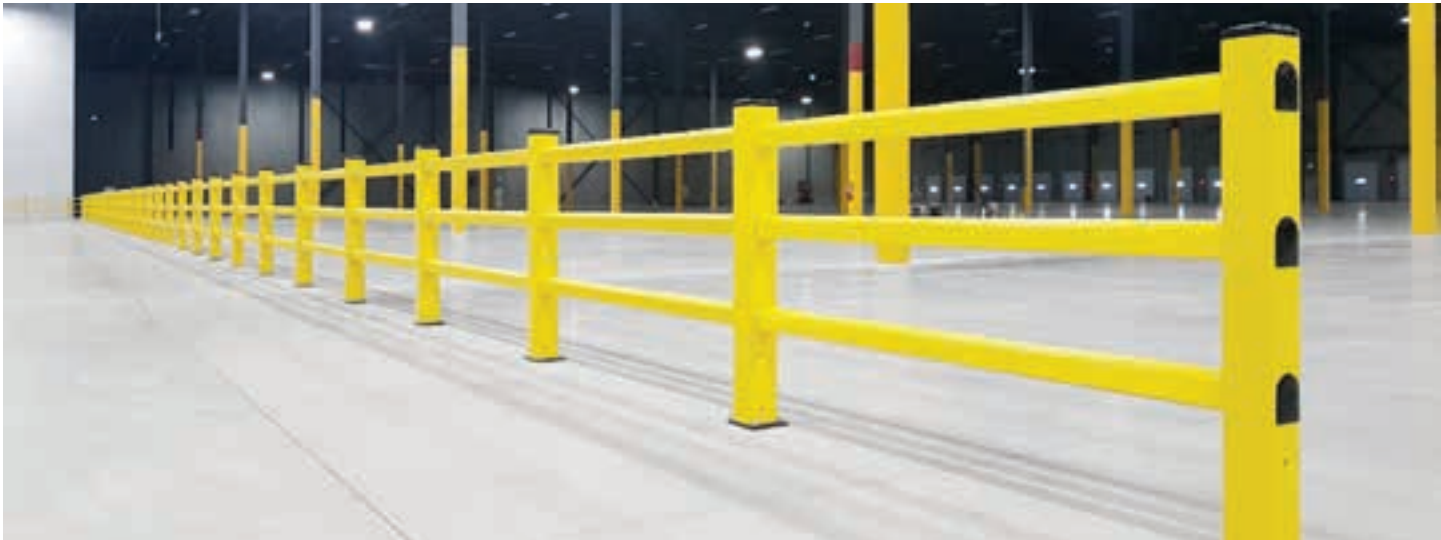
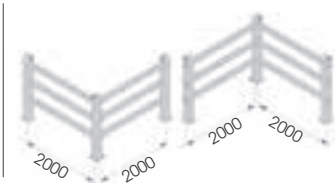

PEDESTRIAN 90 GROUND LEVEL REINFORCED



**S16
GALVANISED STEEL**



PED 90 GL REF

Packing Colour **unpacked on pallet**
B M

Equipped with accessories

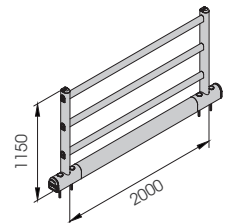

PEDESTRIAN 150 LINK



FAST AND EASY TO INSTALL

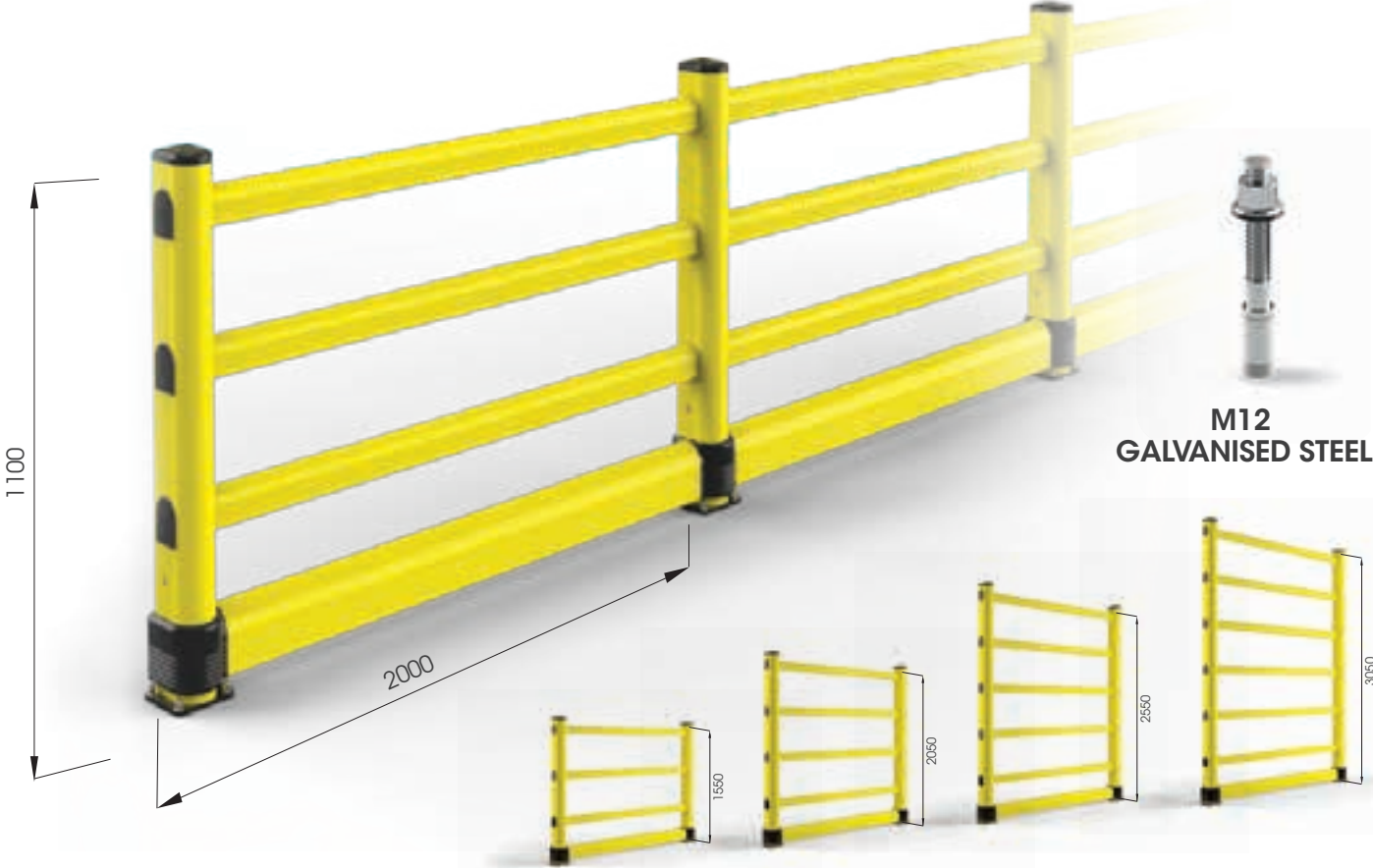

PED 150 LINK

External Corners available

Equipped with accessories

Packing Colour **unpacked on pallet**

B **M**



06

PIN

New pin barrier system, developed with an innovative beam connection mechanism and a new special soft and shock-absorbing gasket. The barrier is even more flexible and resistant to impacts.

**THE BEST HIGH-PERFORMANCE
BARRIER SYSTEM**



Nuovo sistema di barriere pin, progettato con un innovativo meccanismo di connessione dei traversi e una speciale guarnizione morbida ammortizzante. La barriera è ancora più resistente e flessibile all'impatto.

Nouveau système de barrière pin, conçu avec un mécanisme de connexion des traverses innovant et un joint souple spécial amortissant. La barrière est encore plus résistante et flexible aux chocs.

Nuevo sistema de barrera PIN, diseñado con un innovador mecanismo de conexión entre las barras horizontales y con una especial junta de material blando que actúa como un amortiguador. La barrera es aún más resistente y flexible al impacto.

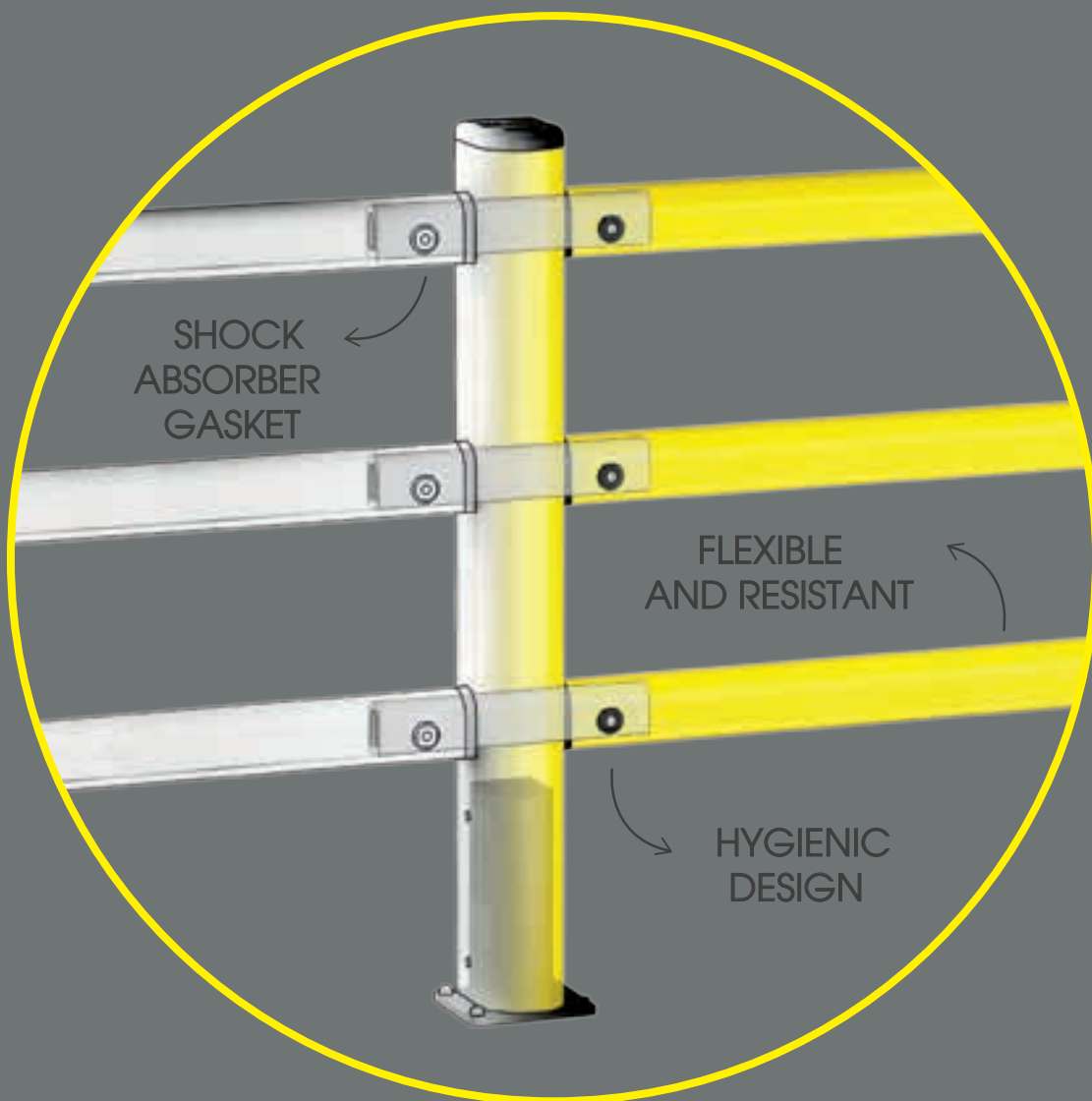

PIN

PED 150 PIN



FAST
AND EASY
TO INSTALL

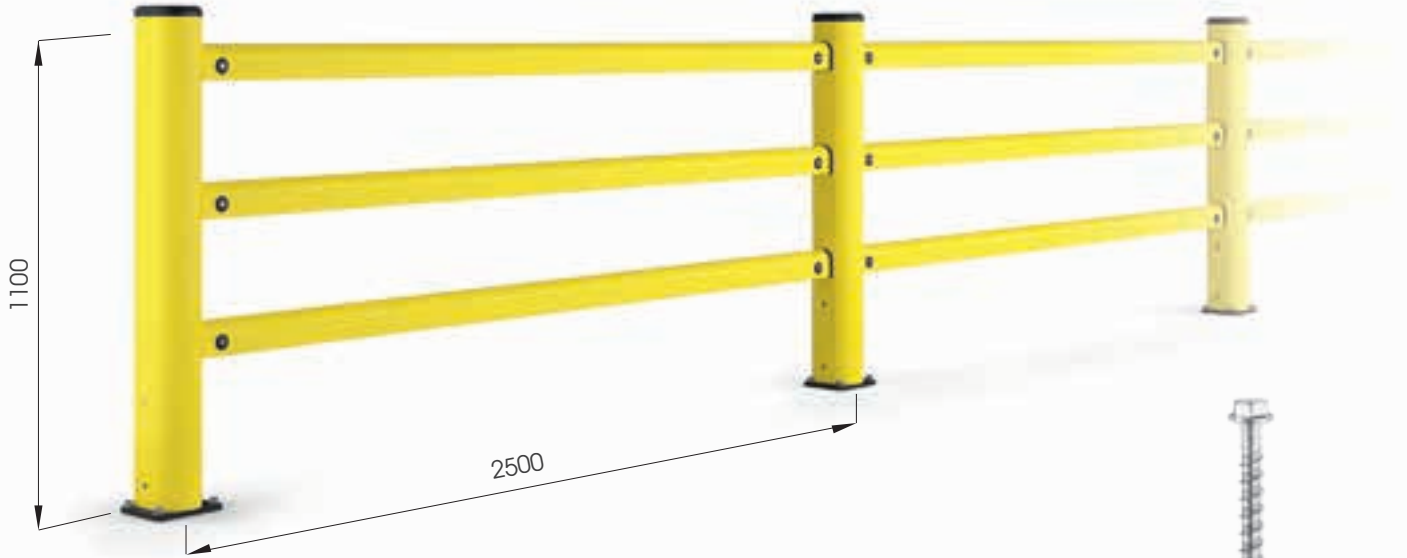

**S12
GALVANISED STEEL**

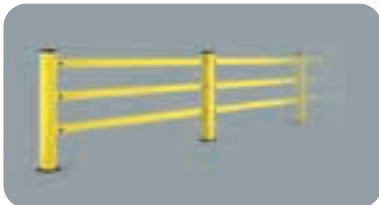

**PED 150 PIN
2500x1150**

Equipped with accessories

Packing **unpacked on pallet**
Colour **B M**



PED 200 PIN



FAST AND EASY TO INSTALL

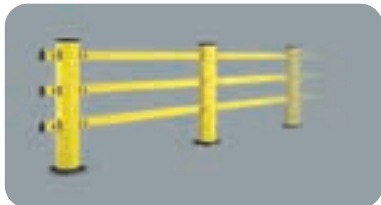

PED 200 PIN
2000x1200

Packing Colour **unpacked on pallet**
M

Equipped with accessories



07

PEDESTRIAN SAFETY GATES

Safety gate system with different opening possibilities, ideated to be installed on our pedestrian barriers. Designed by following an innovative technical design that combines speed and simplicity in the steps of installation and cleaning. Available in different opening systems.



Sistema di cancelli antiurto ideati per l'installazione nelle nostre barriere di protezione per aree pedonali. Progettati seguendo un innovativo disegno tecnico che coniuga rapidità e semplicità nelle fasi di installazione e pulizia. Disponibili molteplici sistemi di apertura.

Système de portillons résistant aux chocs étudié pour l'installation de nos barrières de protections pour les zones piétons. Portillons conçus suivant un design innovant qui combine rapidité et simplicité pendant le montage et le nettoyage. Différents systèmes d'ouvertures disponibles.

Sistema de puertas antigolpe diseñadas para la instalación de nuestras barreras de protección para áreas peatonales. Diseñado según un diseño técnico innovador que une velocidad y simplicidad en las fases de instalación y limpieza. Están disponibles varios sistemas de apertura.

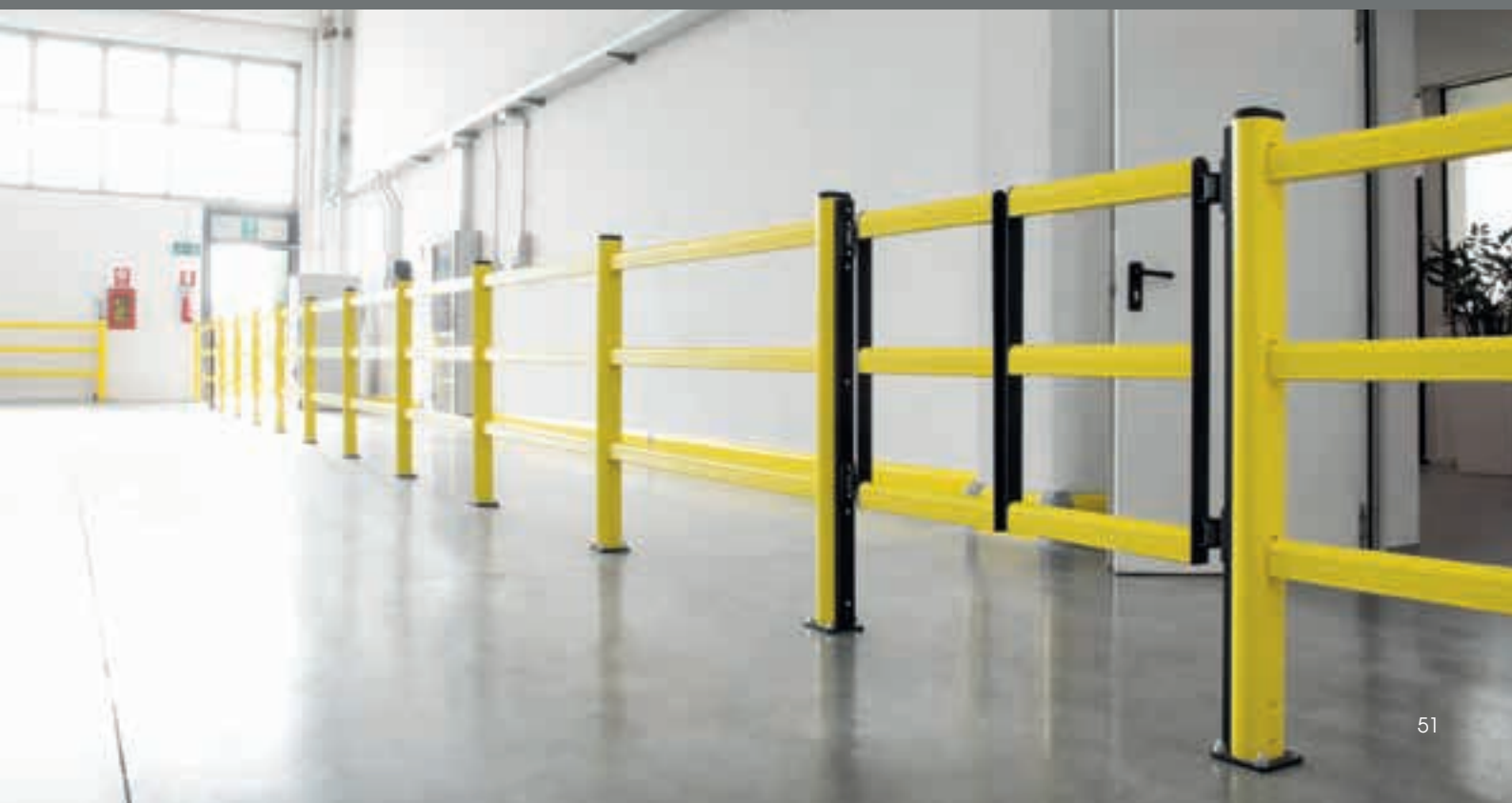

PEDESTRIAN DOOR 90

DIFFERENT SIZES ON REQUEST



DP 90 ONE WAY

Packing Colour **to be defined**
M P



Equipped with accessories

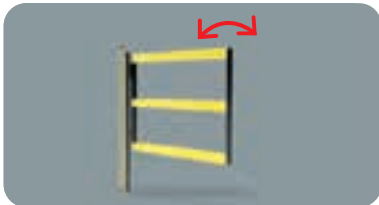

DP 90 SWING

Packing Colour **to be defined**
M P

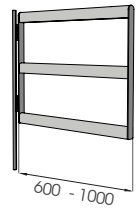

Equipped with accessories

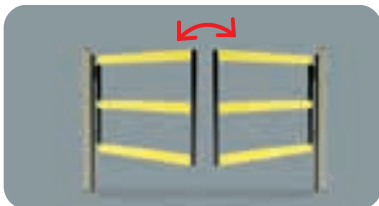

DP 90 SWING DOUBLE

Packing Colour **to be defined**
M P

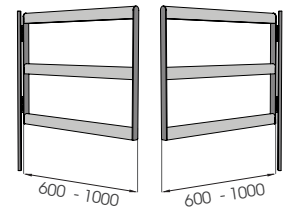

Equipped with accessories



PEDESTRIAN DOOR 150

DIFFERENT SIZES ON REQUEST



NEW SWING OPENING

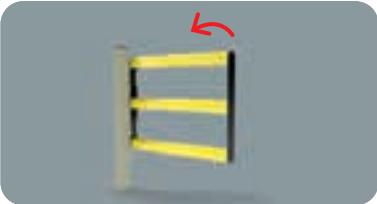

DP 150 ONE WAY

Packing Colour **to be defined**
M P

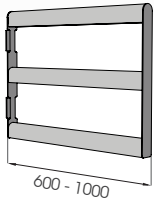

Equipped with accessories

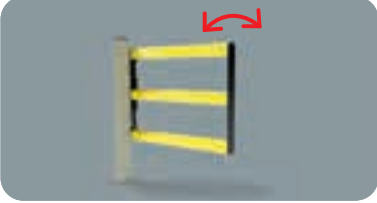

DP 150 SWING

Packing Colour **to be defined**
M P

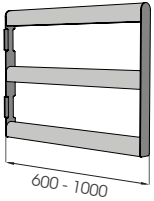

Equipped with accessories

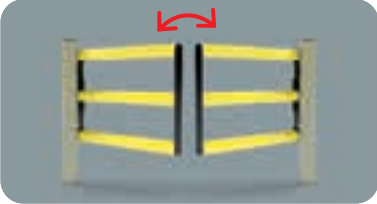

DP 150 SWING DOUBLE

Packing Colour **to be defined**
M P

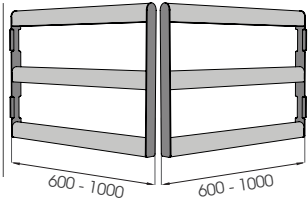

Equipped with accessories



Pedestrian Safety Gates

LIFT GATE 90

DIFFERENT SIZES ON REQUEST

NEW

LIFT GATE 90 DOUBLE



DOUBLE GATE

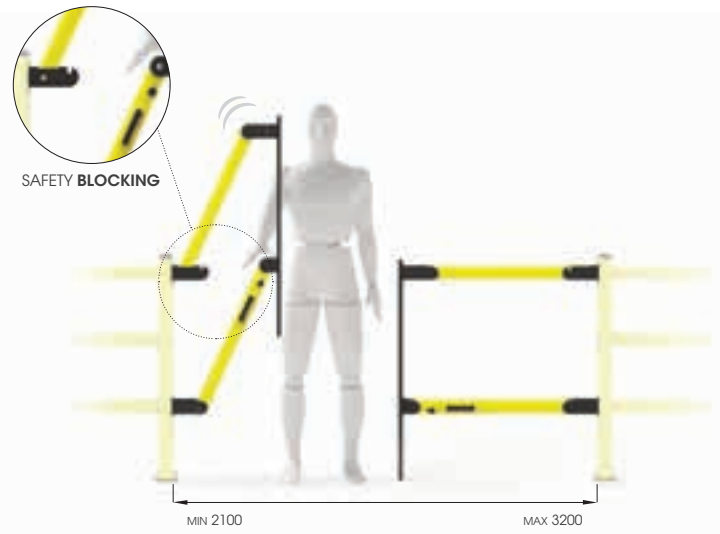
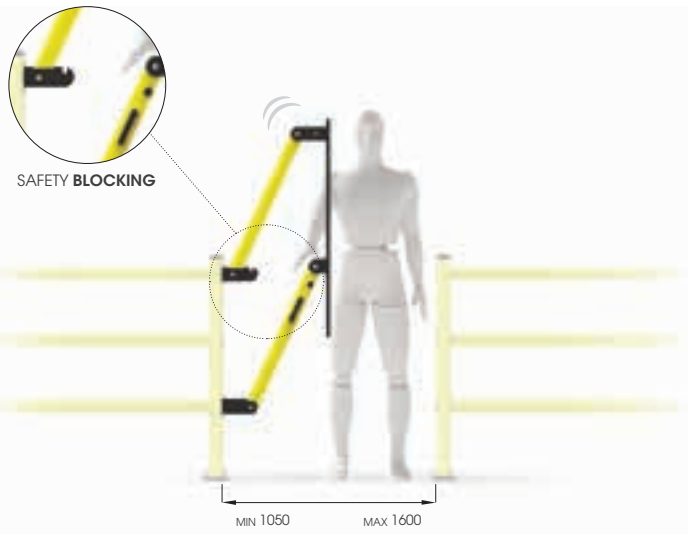

LIFT GATE 90

Packing Colour **to be defined**
M P



Equipped with accessories

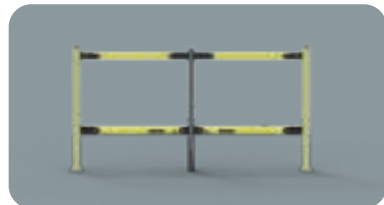

LIFT GATE 90 DOUBLE

Packing Colour **to be defined**
M P

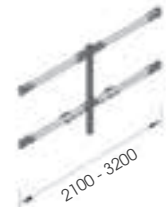

Equipped with accessories



LIFT GATE 150

DIFFERENT SIZES ON REQUEST

NEW

LIFT GATE 150 DOUBLE



DOUBLE GATE

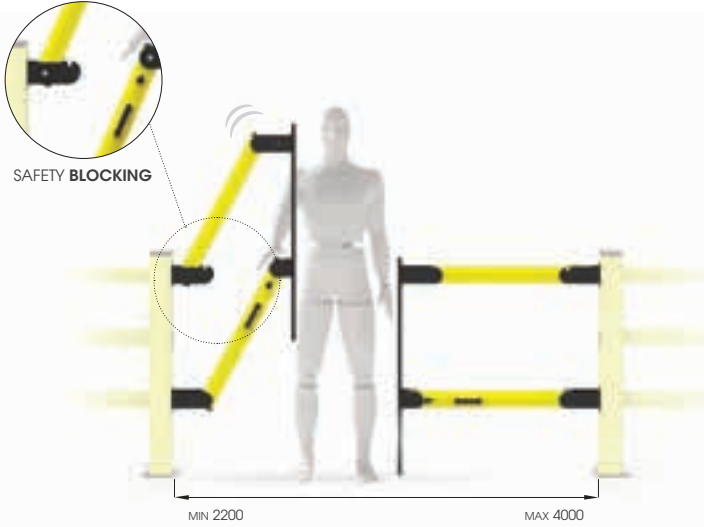
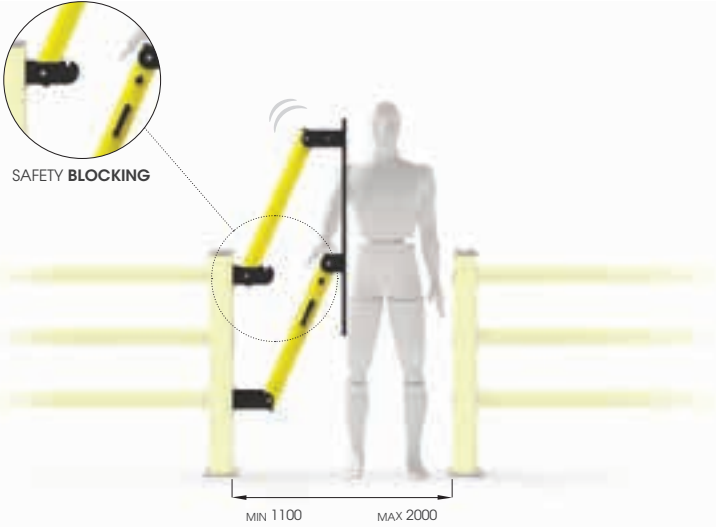

LIFT GATE 150

Packing Colour **to be defined**
M P

Equipped with accessories

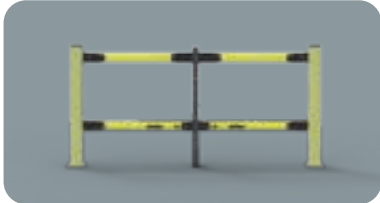

LIFT GATE 150 DOUBLE

Packing Colour **to be defined**
M P

Equipped with accessories

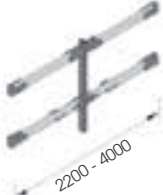

08

LINK – TRAFFIC BARRIER

First adaptable barrier in the world thanks to the new connection system. Rail adjustable height, easy to set up, higher resistance in the most critical points.

Prima barriera al mondo regolabile a piacimento con nuovo sistema di raccordo. Altezza regolabile, facilmente componibile, resistenza potenziata nei punti più critici.

Première barrière au monde à modifier aux besoins avec un nouveau système de jonction. Hauteur à changer, facile à assembler et résistance renforcée aux points plus compliqués.

Primera barrera ajustable en el mundo gracias a un nuevo sistema de conexión. Altura ajustable, de fácil modularidad y resistencia potenciada en los puntos más críticos.



**ADAPTABLE
HEIGHT**



**BASED ON
YOUR
NEEDS**

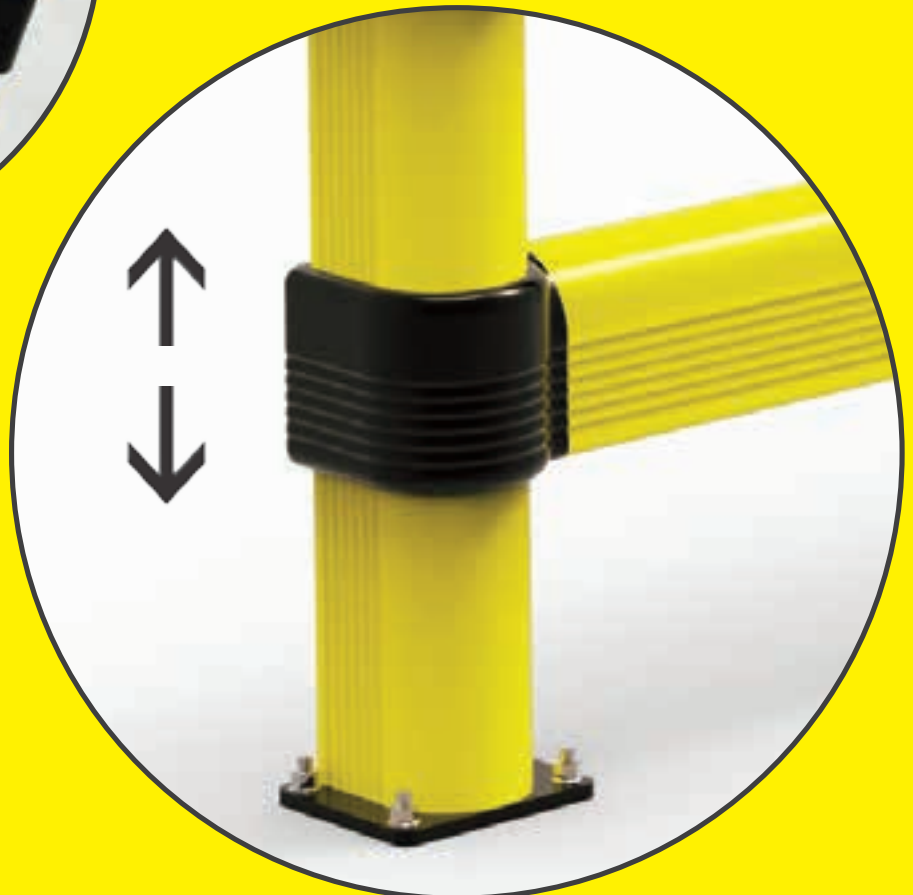

LINK 150/3



DIFFERENT SIZES ON REQUEST

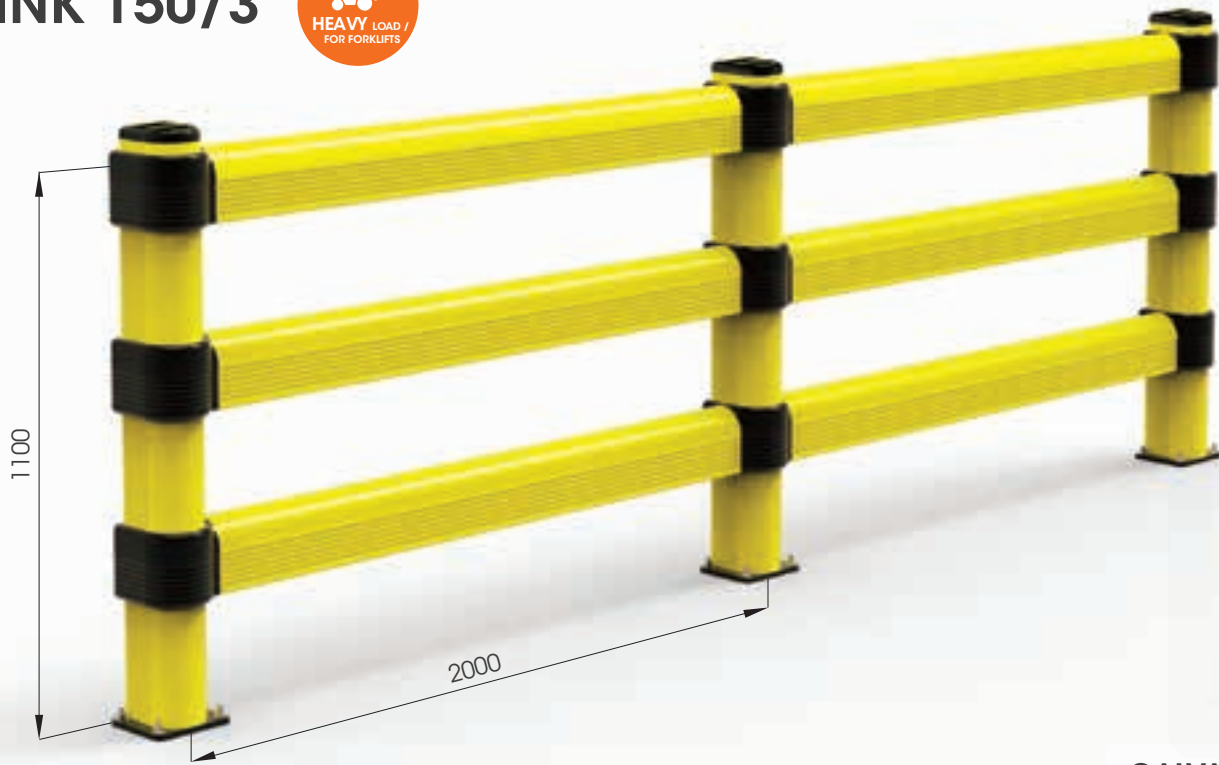

M12 GALVANISED STEEL

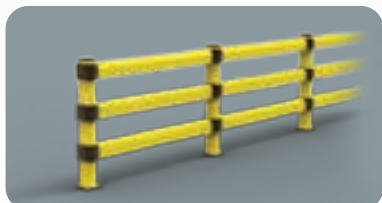

LINK 150/3

Packing Colour **unpacked on pallet**
 B M

Equipped with accessories



LINK 150/3 CORNER

External Corners available

Packing Colour **unpacked on pallet**
 B M

Equipped with accessories

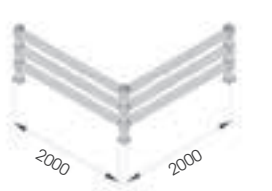

Link - Traffic Barrier

LINK 150/2



DIFFERENT SIZES ON REQUEST

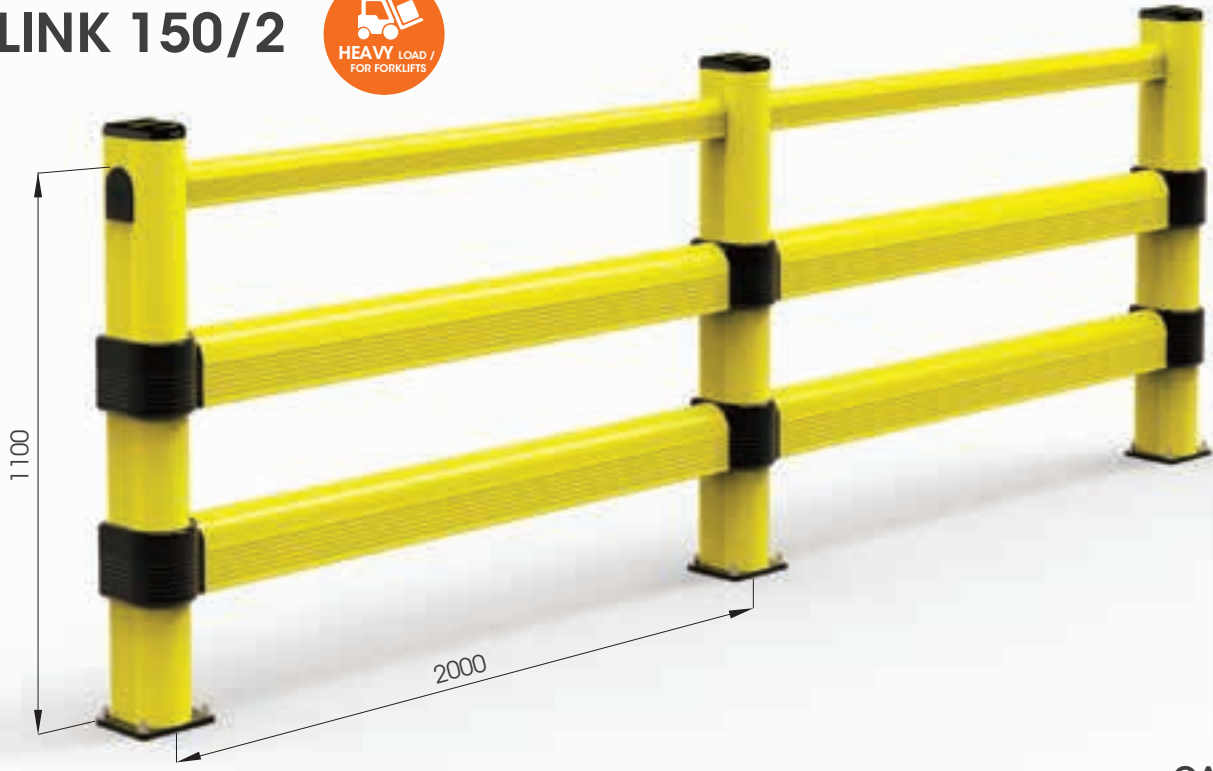

M12 GALVANISED STEEL

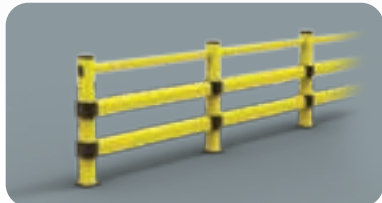

LINK 150/2

Equipped with accessories

Packing Colour **unpacked on pallet**

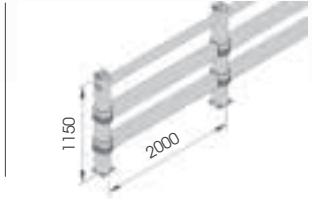

LINK 150/2 CORNER

External Corners available

Equipped with accessories

Packing Colour **unpacked on pallet**

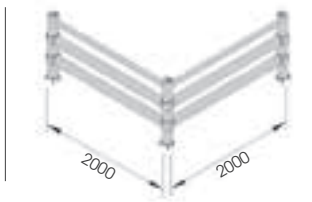

LINK 150/1



DIFFERENT SIZES ON REQUEST



M12 GALVANISED STEEL



LINK 150/1

Packing Colour **unpacked on pallet**
 Colour **B M**



Equipped with accessories



LINK 150/1 CORNER

Packing Colour **unpacked on pallet**
 Colour **B M**



External Corners available

Equipped with accessories



Link - Traffic Barrier

LINK LM



DIFFERENT SIZES ON REQUEST

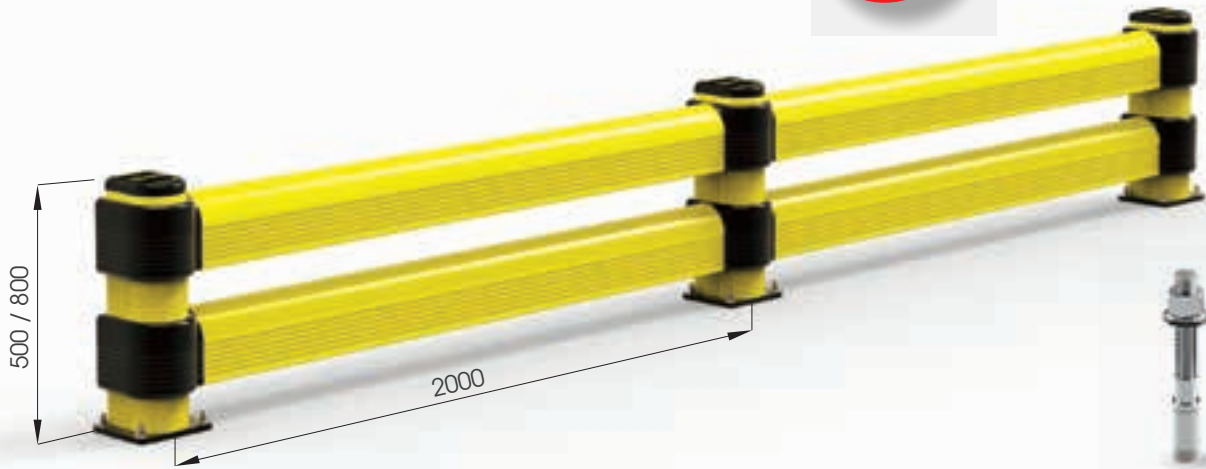

M12 GALVANISED STEEL

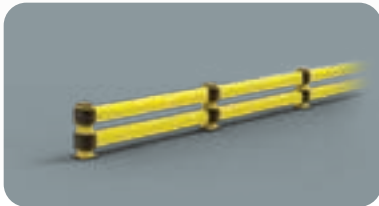

LINK LM 500 800

Packing Colour **unpacked on pallet**
 B M



Equipped with accessories



LINK LM CORNER

Packing Colour **unpacked on pallet**
 B M

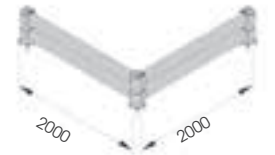

External Corners available

Equipped with accessories



LINK SINGLE



DIFFERENT SIZES ON REQUEST

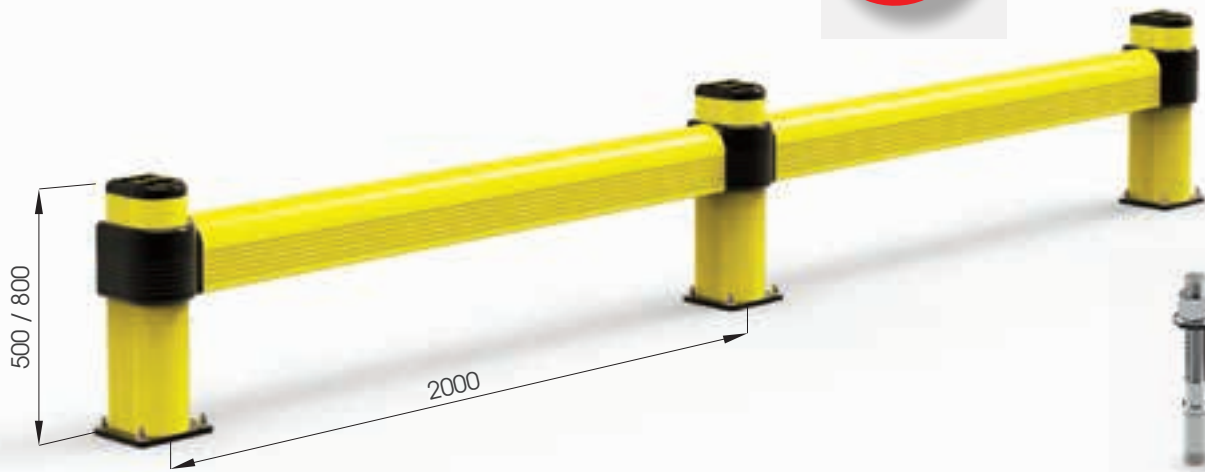

M12 GALVANISED STEEL

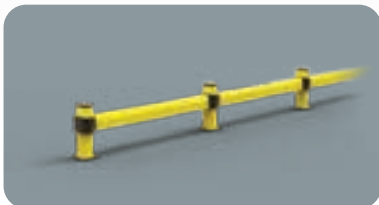

LINK SINGLE 500 800

Packing Colour **unpacked on pallet**
 B M

Equipped with accessories



LINK SINGLE CORNER

Packing Colour **unpacked on pallet**
 B M

External Corners available

Equipped with accessories



LINK 120



LINK 120/1

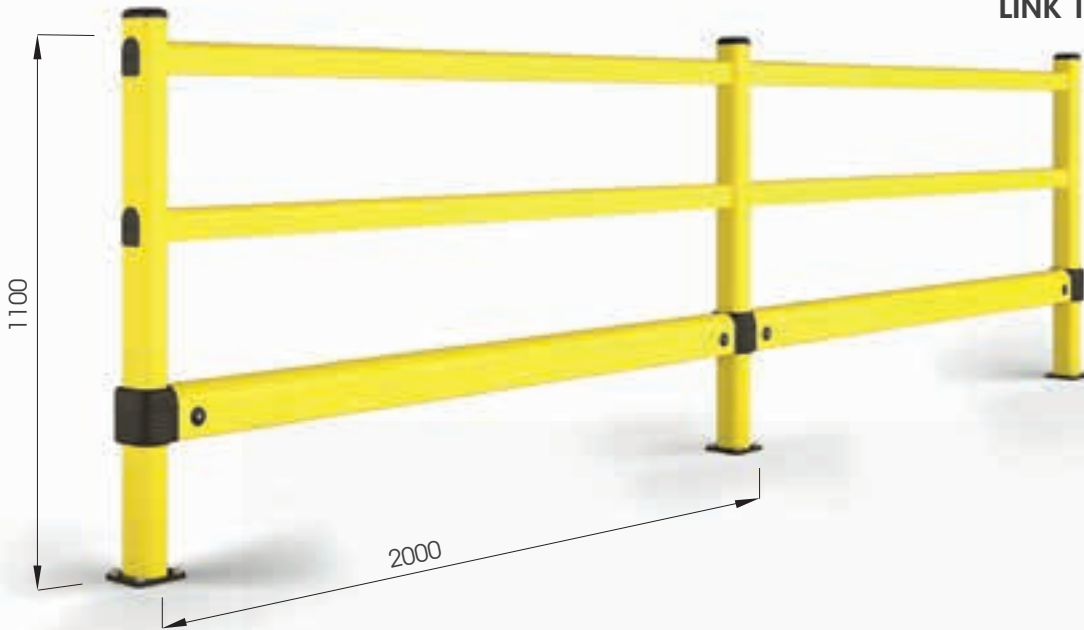

S12
GALVANISED STEEL

LINK 120/2

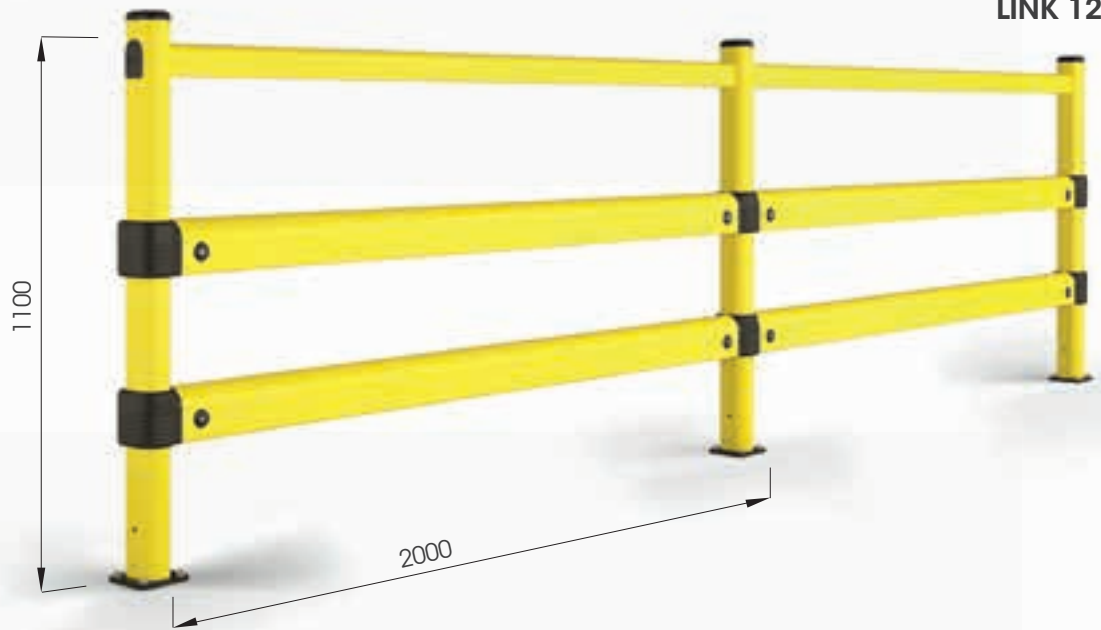

LINK 120/3

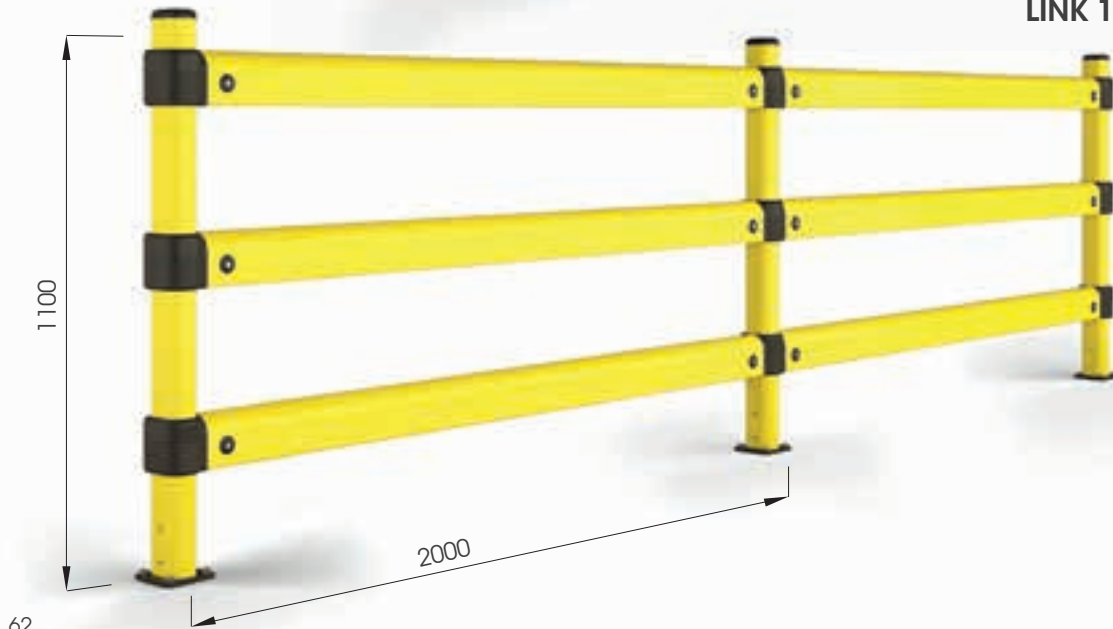

FLEXIBLE PROTECTIONS

REMOVABLE PLATE

COVER 90 RE

AVAILABLE FOR:
SM / FENCE 90 / HR 90 / PED 90

COVER 150 RE

AVAILABLE FOR:
LINK / LM / FENCE 150 / PED 150



09

B FLEX – SAFETY BARRIER SYSTEM

New protection system with a reinforced profile, twice as flexible and shock-absorbing. Planned and developed with a specific design to ensure high safety standards and to resist impacts from heavy loads. Available in many different versions.



Nuovo sistema di protezioni con profilo rinforzato, doppiamente flessibile e assorbente. Progettato e realizzato con un particolare design per garantire alti livelli di sicurezza e resistere all'impatto da carichi pesanti. Disponibile in diverse versioni.

Nouveau système de protection avec profil renforcé, doublement flexible et absorbant. Conçu et produit avec un design particulier pour assurer des niveaux élevés de sécurité et résister à l'impact des charges lourdes. Disponible en plusieurs versions.

Nuevo sistema de protección con perfil reforzado, más flexible y capaz de absorber perfectamente los impactos. Diseñado para asegurar el entorno laboral y para resistir a los impactos de cargas pesadas. Disponible en diferentes versiones.

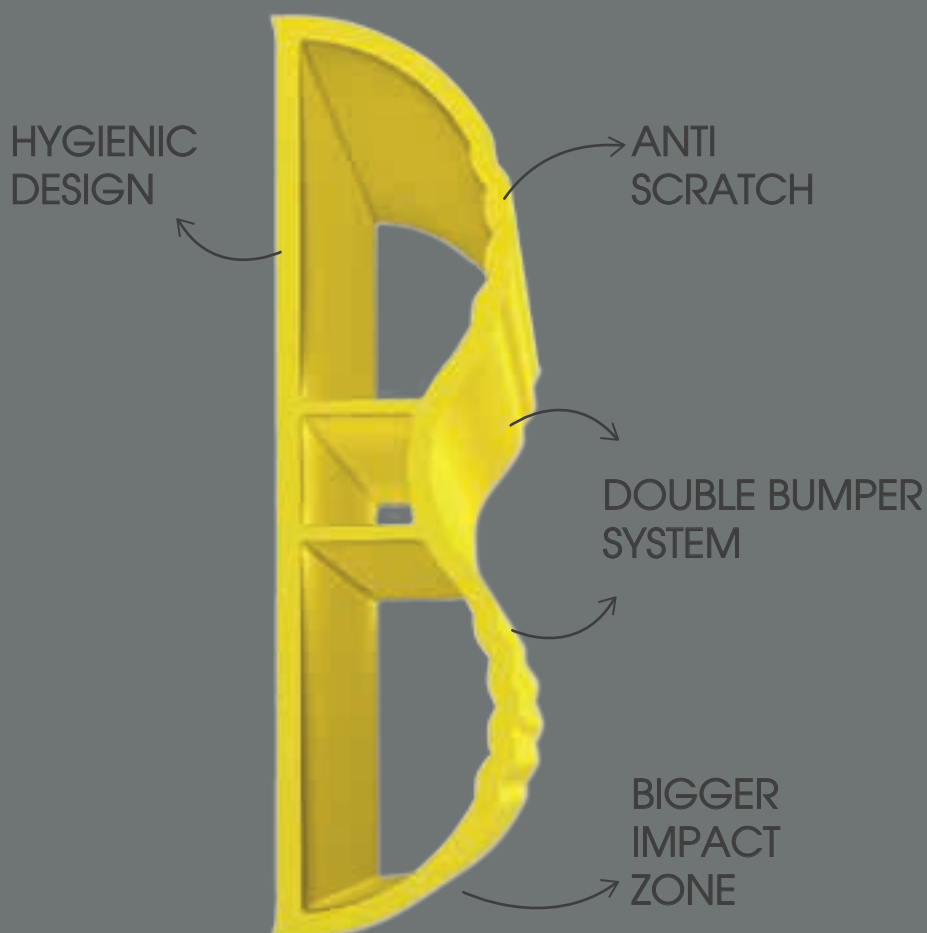

BFlex – Safety Barrier System

B FLEX.FRONT/1



BFLEX.FRONT/1 1100x450
BFLEX.FRONT/1 2400x450

Length **1.100 / 2.400 mm**
 Packing **unpacked on pallet**
 Colour **M**

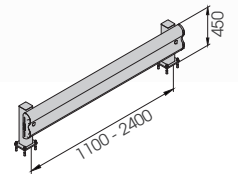

Equipped with accessories



BFLEX.FRONT/1 2000x450
MODULAR

Packing **unpacked on pallet**
 Colour **M**

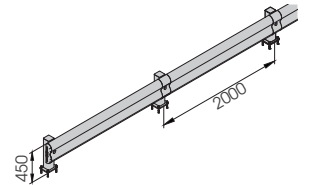

Equipped with accessories



BFLEX.FRONT/2



INCLUDED

S12 x 150 GALVANISED STEEL



BFLEX.FRONT/2 1100x1100
BFLEX.FRONT/2 2400x1100

Length **1.100 / 2.400 mm**
Packing **unpacked on pallet**
Colour **M**

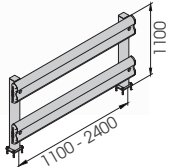

Equipped with accessories



BFLEX.FRONT/2 2000x1100 MODULAR

Packing **unpacked on pallet**
Colour **M**

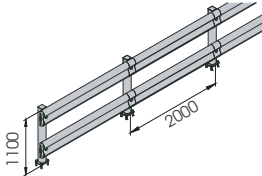

Equipped with accessories



BFlex – Safety Barrier System

BFLEX.COM/1

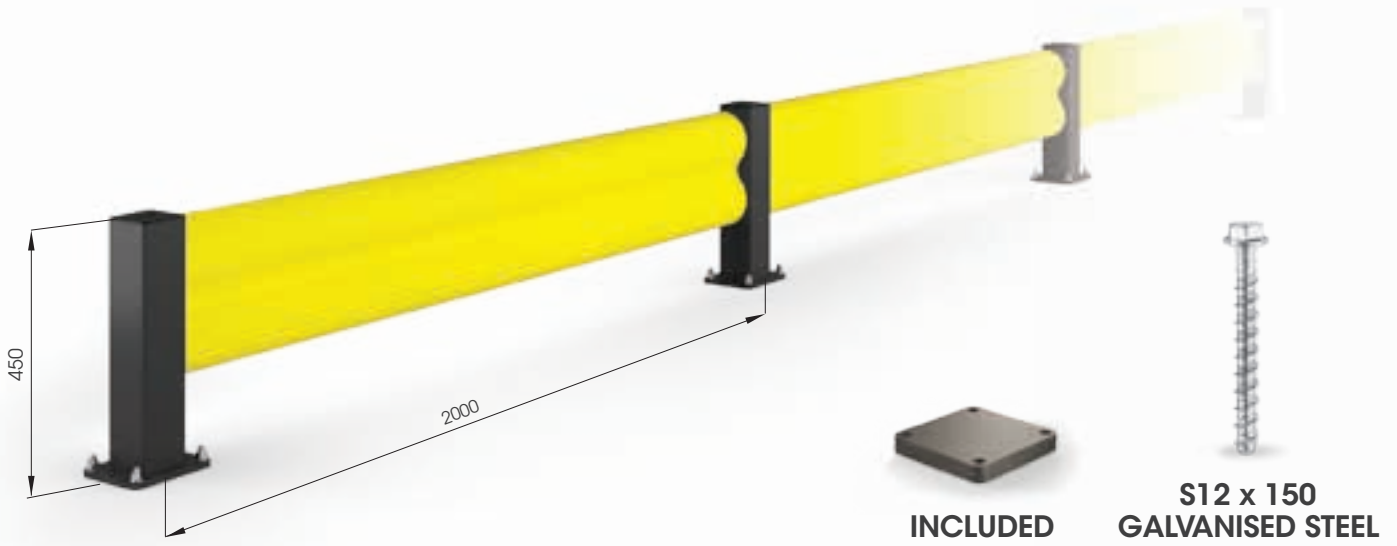

BFLEX.COM/1 1100x450
BFLEX.COM/1 2400x450

Length **1.100 / 2.400 mm**
Packing **unpacked on pallet**
Colour **M**

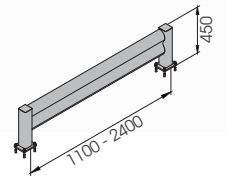

Equipped with accessories



BFLEX.COM/1 2000x450
MODULAR

Packing **unpacked on pallet**
Colour **M**

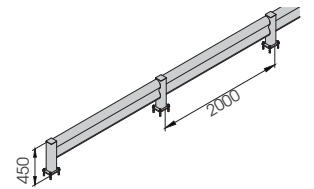

Corners available

Equipped with accessories



BFLEX.COM/2



BFLEX.COM/2 1100x1100
BFLEX.COM/2 2400x1100

Length **1.100 / 2.400 mm**
Packing **unpacked on pallet**
Colour **M**

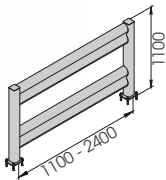

Equipped with accessories



BFLEX.COM/2 2000x1100
MODULAR

Packing **unpacked on pallet**
Colour **M**

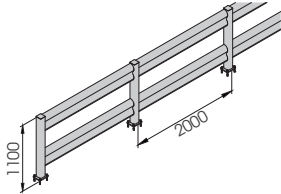

Corners available

Equipped with accessories



10

COLUMN PROTECTION

New bumper system specific for columns protection, strongly resistant to impacts from moving vehicles of different capacities, like pallet trucks and forklifts. Developed by following an innovative technical design that combines speed and simplicity during installation and cleaning. Available in different heights and fixing systems.

Sistema di profili specifico per la protezione delle colonne dai carrelli in movimento di varie portate. Progettato seguendo un innovativo disegno tecnico che coniuga rapidità e semplicità nelle fasi di installazione e pulizia. Disponibile in diverse altezze e tipologie di fissaggio.

Nouveau système bumper, spécifique pour protéger les poteaux contre les mouvements des chariots. Étudié avec un modern dessin qui regroupe la rapidité et la facilité pendant l'installation et le nettoyage. Disponible en différents hauteurs et différents fixations.

Sistema de perfiles específico para la protección de las columnas de los carros en movimiento de diferentes capacidades. Diseñado según un innovador diseño técnico que une velocidad y simplicidad en las fases de instalación y limpieza. Disponible en diferentes alturas y tipos de fijación.



- REMOVABLE
- NO SCRATCHES
- VERY SOLID AND SLIM DESIGN
- NO FIXING IS REQUIRED

MINI HUG TOWER

1100

DIFFERENT SIZES AND HEIGHT ON REQUEST

COMPACT



NO HOLES ON THE FLOOR AND COLUMN!



MINI HUG TOWER

Packing Colour **to be defined**
M

Equipped with accessories

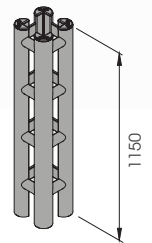

HUG TOWER 3 SIDES



DIFFERENT SIZES ON REQUEST



WALL FIXING WITH S8FH GALVANISED STEEL

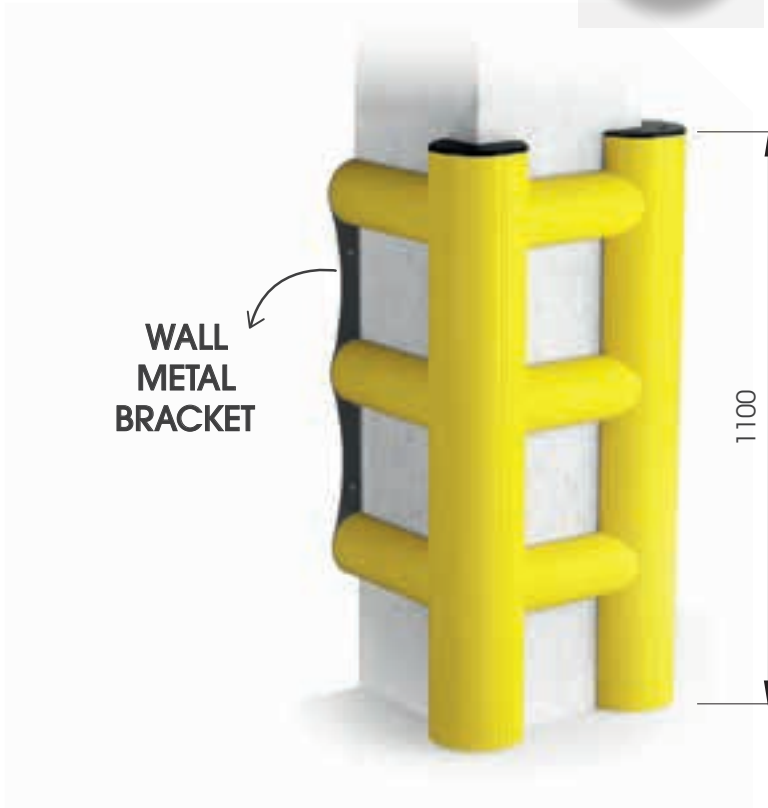

WALL METAL BRACKET

1100

COMPACT



NO HOLES ON THE FLOOR AND COLUMN!



HUG TOWER 3 SIDES

Also 2 SIDES available

Equipped with accessories

Packing Colour to be defined

M



1150



HUG TOWER



DIFFERENT SIZES AND HEIGHT ON REQUEST

COMPACT



NO HOLES ON THE FLOOR AND COLUMN!

CHOOSE THE HEIGHT YOU NEED!

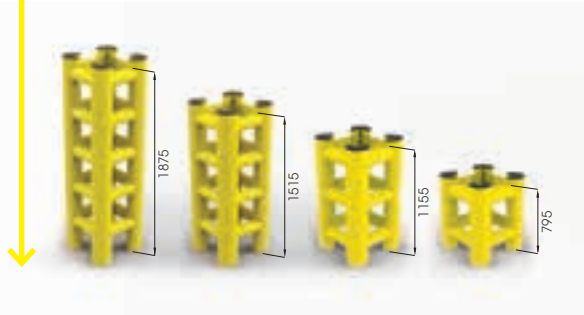

1100

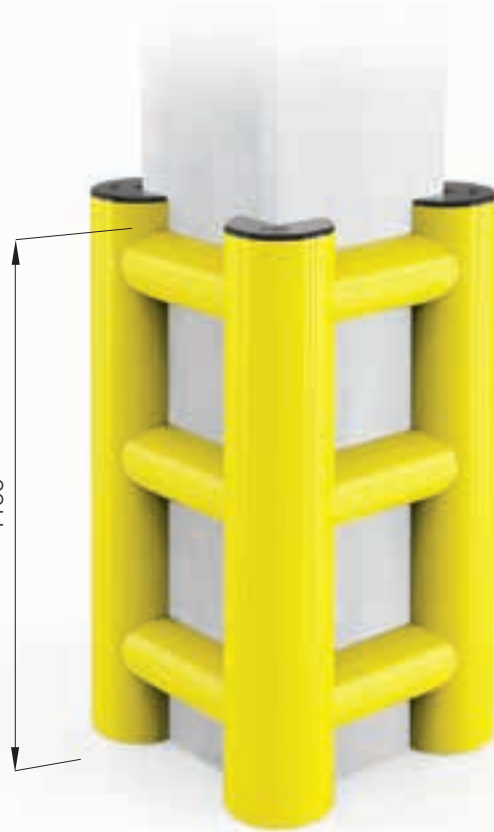

HUG TOWER

Packing Colour **to be defined**
M

Equipped with accessories



TOWER PROTECTION



DIFFERENT SIZES AND HEIGHT ON REQUEST



M12 GALVANISED STEEL

AVAILABLE ALSO:

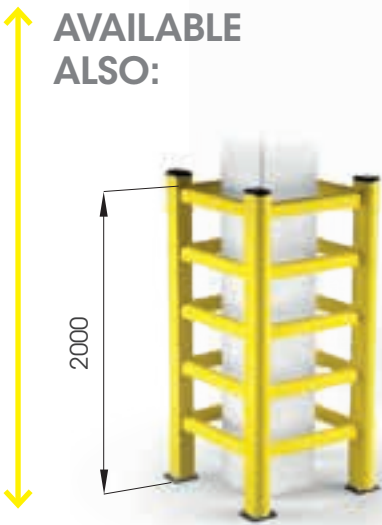

1100



TOWER

Also 2/3 SIDES available

Equipped with accessories

Packing Colour **to be defined**
B M



TOWER LINK



DIFFERENT SIZES AND HEIGHT ON REQUEST



M12 GALVANISED STEEL



OPTIONS



TOWER LINK/1



TOWER LINK/2



TOWER LINK/3



TOWER LINK/1
TOWER LINK/2
TOWER LINK/3

Equipped with accessories

Packing Colour to be defined
B M

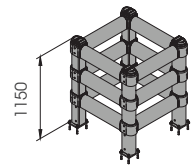

Column protection

COLUMN PROTECTION 90



DIFFERENT SIZES ON REQUEST

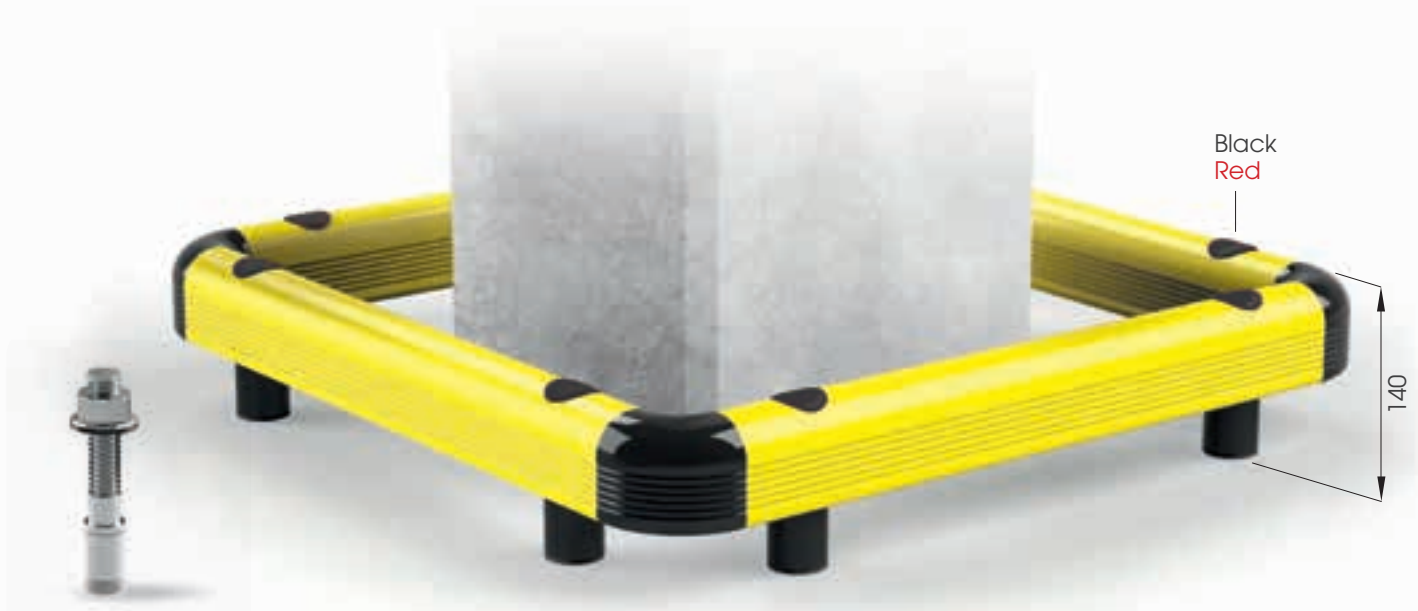

Black
Red

140

M16
STAINLESS STEEL



COPRO 90

Also 2/3 SIDES
available

Equipped with accessories

Packing Colour **unpacked on pallet**

B M



90



COLUMN PROTECTION 150



DIFFERENT SIZES ON REQUEST



SF20
STAINLESS STEEL



COPRO 150

Also 2/3 SIDES available

Equipped with accessories

Packing Colour

unpacked on pallet



SOFT HUG

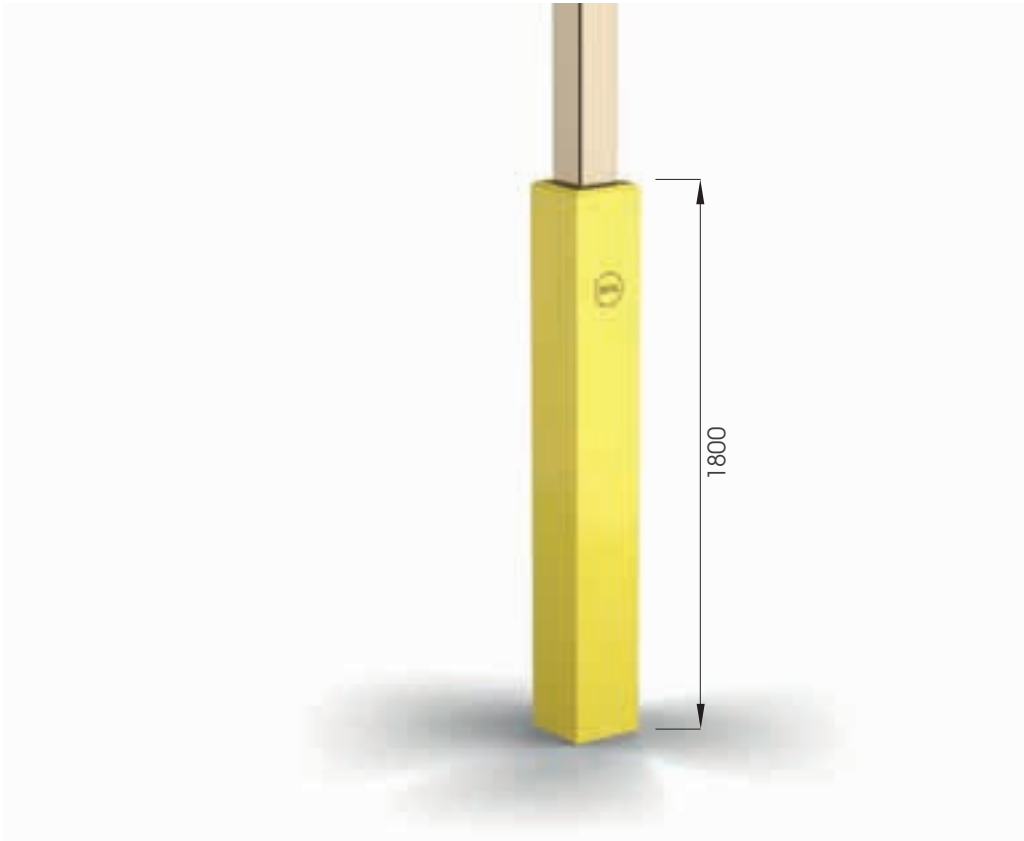

COMPACT
& SOFT

VELCRO
OPENING



SOFT HUG

Packing Colour **to be defined**

M



CHOOSE THE SIZE YOU NEED!



SOLUTIONS FOR COLUMNS AND PILLARS

COLUMN PROTECTIONS

▶ APPLICATION

On columns and pillars, also on just two or three sides

▶ SAFETY

- Safeguard load-bearing columns and pillars to avoid structural damage to buildings
- Prevent physical trauma of vehicle operators due to shock loads resulting from impact against a column
- Provide a visual guide for forklift operators

▶ SAVING

- Zero maintenance and damage to corners, projecting parts, and columns
- Prevent damage to vehicles

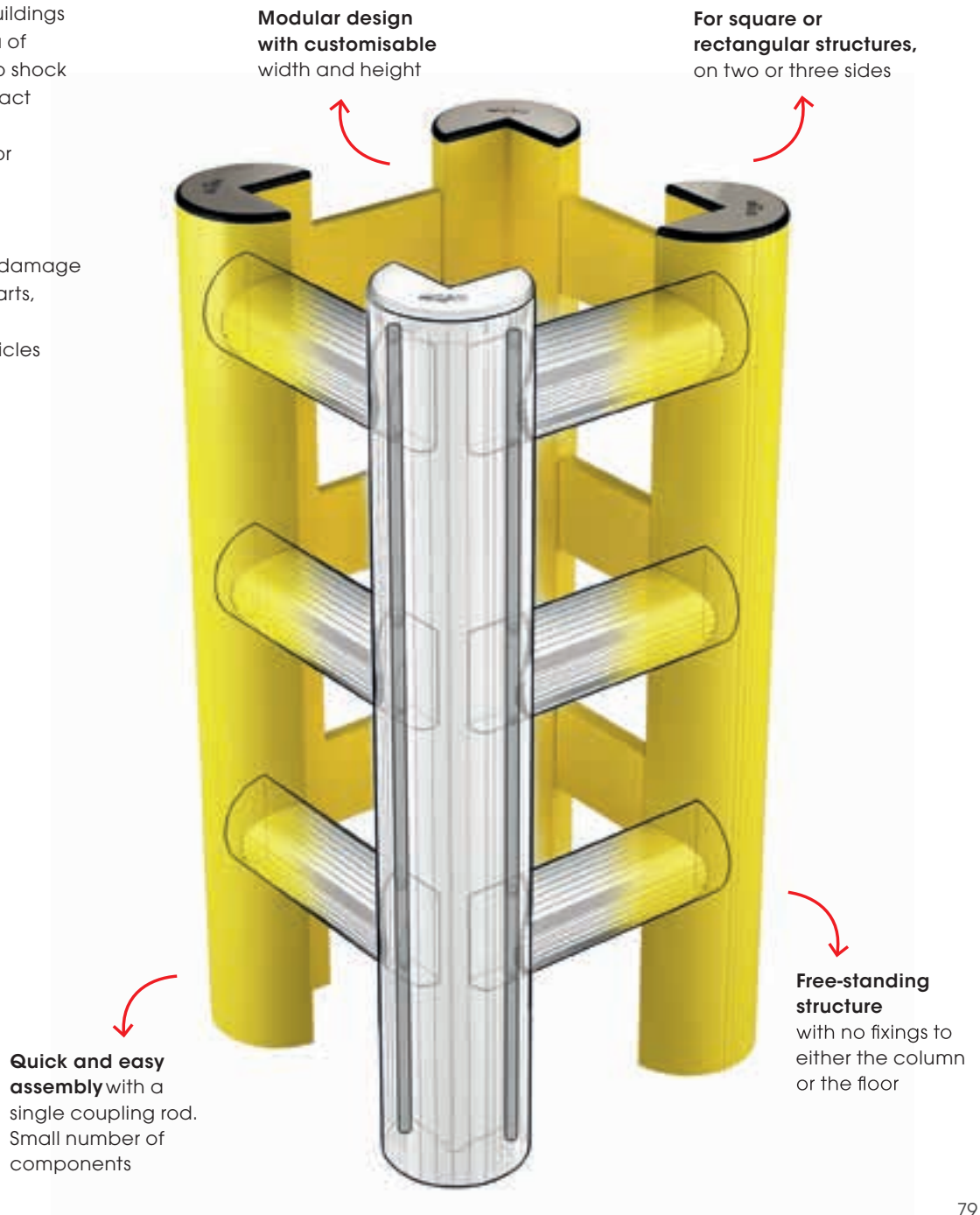

11

ACCESS/ EGRESS PROTECTION

Protection system has been designed to prevent forklifts collisions with overhead infrastructure and gates and doors jambs. It is created to keep under control the passage of forklifts that exceed height limits, attracting the attention of drivers and inviting them to a more careful guide. Useful to protect gates, loading docks or overhead assets. Available in different lengths.

Sistema di protezione ideato per prevenire le collisioni dei carrelli elevatori in movimento con le infrastrutture sopraelevate e gli stipiti di porte e portoni. Limita il passaggio di carrelli che superano i limiti di altezza, attirando l'attenzione dei carrellisti e invitandoli ad una guida più accorta. L'installazione è consigliata in prossimità di portoni, baie di carico o di attrezzature sospese. Disponibile in diverse lunghezze.

Systèmes de protection conçus pour prévenir les collisions des chariots élévateurs en mouvement avec les infrastructures en hauteur et les montants des portes. Utiles pour empêcher le passage des chariots élévateurs qui dépassent les limites d'hauteur, pour attirer l'attention des conducteurs et de les habituer à faire plus attention à la conduite des chariots. C'est installé en proximité des bords des portes, quais de chargement et infrastructures suspendues. Disponible en plusieurs longueurs.

Sistema de protección diseñado para evitar la colisión de carretillas elevadoras en movimiento con infraestructuras, instalaciones elevadas y marcos de puertas industriales. Diseñada para limitar el paso de las carretillas que superan los límites de altura, llamando la atención de los conductores de montacargas e invitándoles a conducir con más cuidado. Se recomienda su instalación cerca de puertas industriales, muelles de carga o equipos suspendidos. Disponible en varias longitudes.



WARNING BAR



WBAR

Length 2000 / 3000 mm
Packing to be defined
Colour **M**

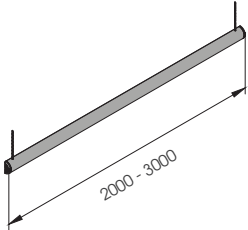

Equipped with accessories



WARNING BAR / INFORMATION SIGN



WBIS

Length 2000 / 3000 mm
Packing to be defined
Colour **M**

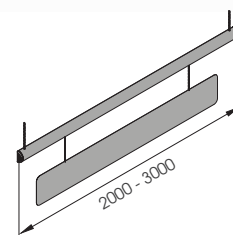

Equipped with accessories



WARNING BAR / LIGHT & SOUND 102dB



102dB



HEAVY LOAD /
FOR FORKLIFTS



UP TO
70.000
IMPACTS!



WBLS

Equipped with accessories

Length 2000 / 3000 mm
Packing to be defined
Colour M

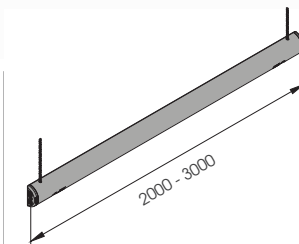

FULL FRAME SELF STANDING



DIFFERENT SIZES ON REQUEST

FAST AND EASY TO INSTALL

NEW BIGGER PLATES!

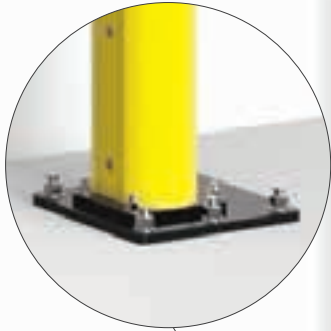

FFB SELF STANDING

Packing Colour **to be defined**



Equipped with accessories



FULL FRAME WALL FIXING



DIFFERENT SIZES ON REQUEST

FAST AND EASY TO INSTALL

WALL FIXING ACCESSORIES

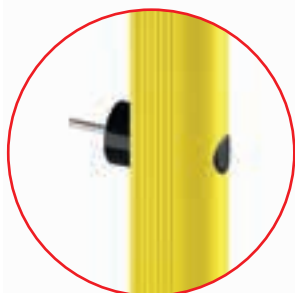

M12 GALVANISED STEEL



FFB WALL FIXING

Packing Colour **to be defined**

M



Equipped with accessories



12

LOADING DOCK SAFETY

Loading bays protections are shock-proof solutions which are set up near loading doors. They avoid possible slipping, falling and flipping of moving vehicles near open and unmanned loading bays.

Sistema di protezione antiurto installato in prossimità delle porte di carico. Permettono di evitare situazioni ad alto rischio di scivolamento, caduta e ribaltamento dei mezzi in movimento in presenza di baie di carico aperte e non presidiate.

Système de protection contre les chocs installé près des portes de chargement. Ils permettent d'éviter des situations en raison du risque élevé de glissement, de chute et de basculement des véhicules en mouvement en présence de quais de chargement ouverts et sans surveillance.

La protección de muelles de carga es un sistema anticolidión que está cerca de las puertas de carga. Evitan los riesgos de deslizamiento, caída y derrocamiento los vehículos en movimiento cuando están cerca de los muelles de carga abiertos y no vigilados.



DOCK BUMPER



DOCK BUMPER

Packing to be defined

Fixing on requests

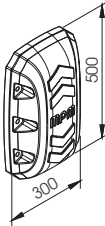

HUG GATE



PUSH TO UNBLOCK



S12
GALVANISED STEEL



HUG GATE

Equipped with accessories

Packing Colour **to be defined**
B M

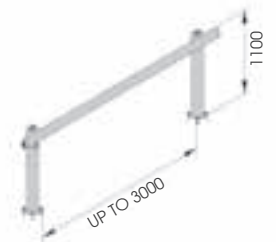

DOCK GATE



**M12
GALVANISED STEEL**



- DOCK GATE L 2400-2600**
- DOCK GATE XL 2605-2800**
- DOCK GATE XXL 2805-3000**

Packing Colour **to be defined**
 B M

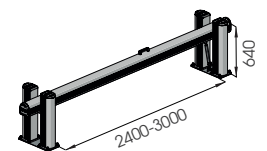

Equipped with accessories



13

WHEEL STOP BARRIER

Solutions designed for the safety of loading and unloading zones in warehouses and parking areas. Ideal for conveying, stopping or positioning the vehicle in the parking area, or near a cargo bay.

Soluzioni progettate per la sicurezza delle zone di carico e scarico dei magazzini e dei parcheggi. Ideali per convogliare, fermare o posizionare il mezzo nell'area di parcheggio o in prossimità di una baia di carico.

Solutions conçues pour la sécurité des zones de chargement et de déchargement des entrepôts et parkings. Idéal pour transporter, arrêter ou positionner le véhicule dans l'aire de stationnement ou à proximité d'un quai de chargement.

Soluciones diseñadas para asegurar las zonas de carga y descarga de almacenes y aparcamientos. Ideal para transportar, detener o posicionar el vehículo en la zona de aparcamiento o cerca de un muelle de carga.



Wheel Stop Barrier

TRUCK LINE



DIFFERENT SIZES ON REQUEST

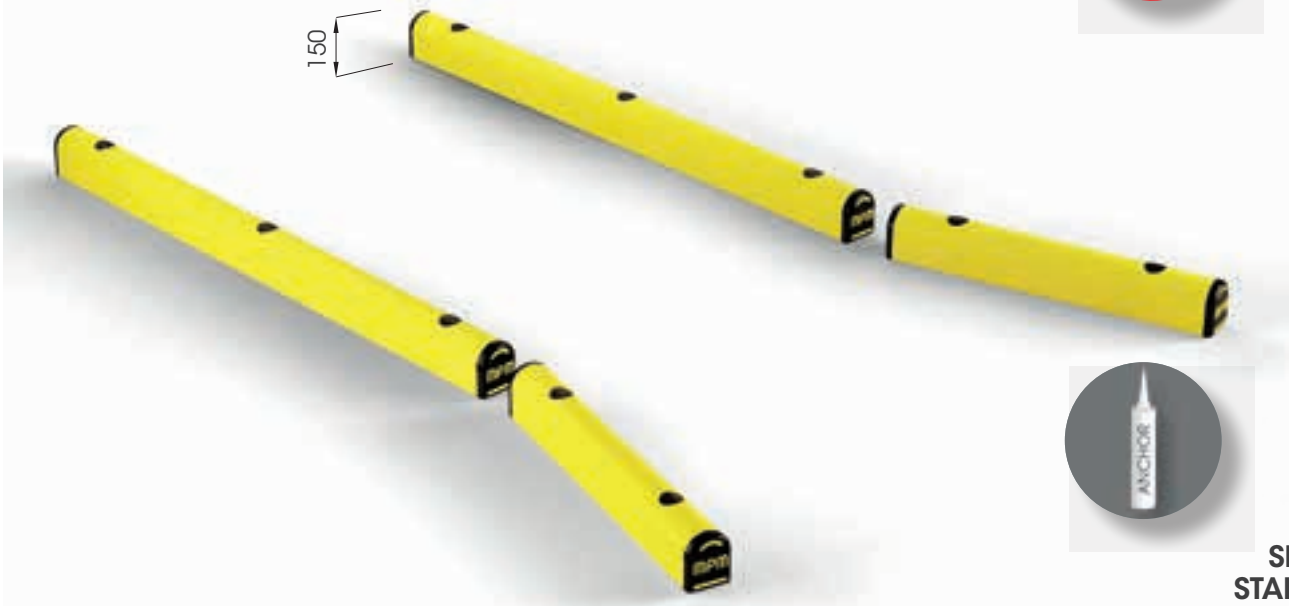

**SF20 x 200
STAINLESS STEEL**



TL	500	2000
	750	3000
	1000	4000
	1500	

Packing Colour **to be defined**
 B M



Equipped with accessories



CAR STOP

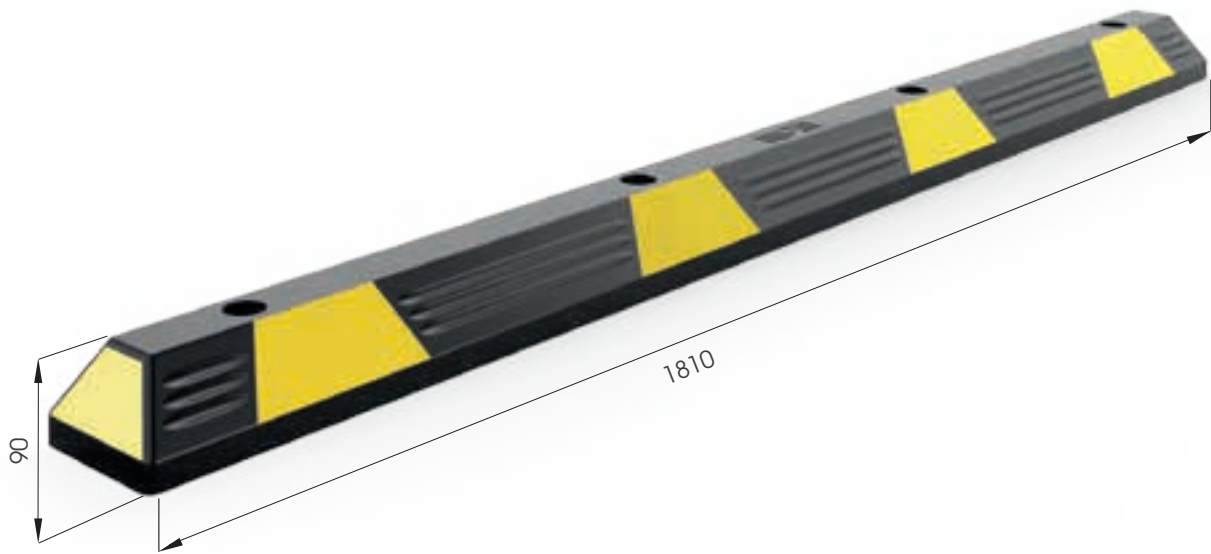

CAR STOP

Packing **to be defined**

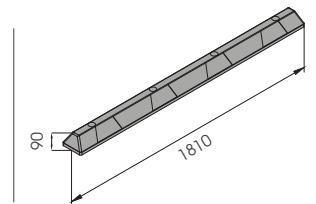

Fixing on requests



TRUCK STOP

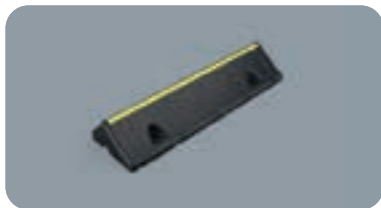
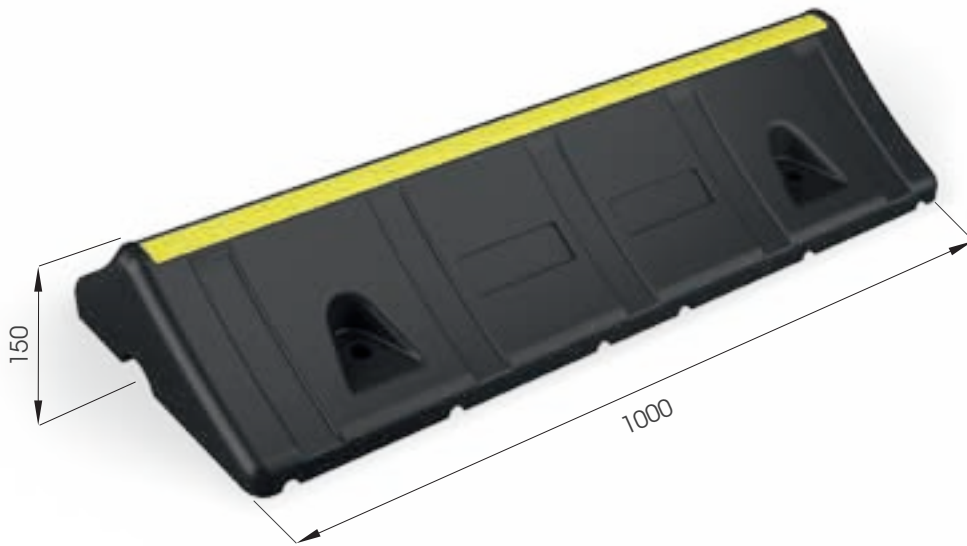

TRUCK STOP

Packing to be defined

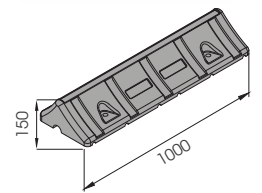

Fixing on requests



14

CABLE COVER

Floor cable protection system in soft material. Space-saving, resistant and easy-to-install cable cover. Suitable for work areas with pedestrian passage.

Sistema di protezione morbido a pavimento per cavi. Passacavi poco ingombrante, resistente e facile da posare. Adatto ad aree di lavoro con passaggio di pedoni.

Système de protection de sol souple pour câbles. Guide-câble peu encombrant, résistant et facile à installer. Convient aux zones de travail avec passage piéton.

Sistema de protección blando de suelo para los cables. Pasacables que ahorra espacio, es duradero y fácil de instalar. Adecuado para zonas de trabajo con tráfico peatonal.

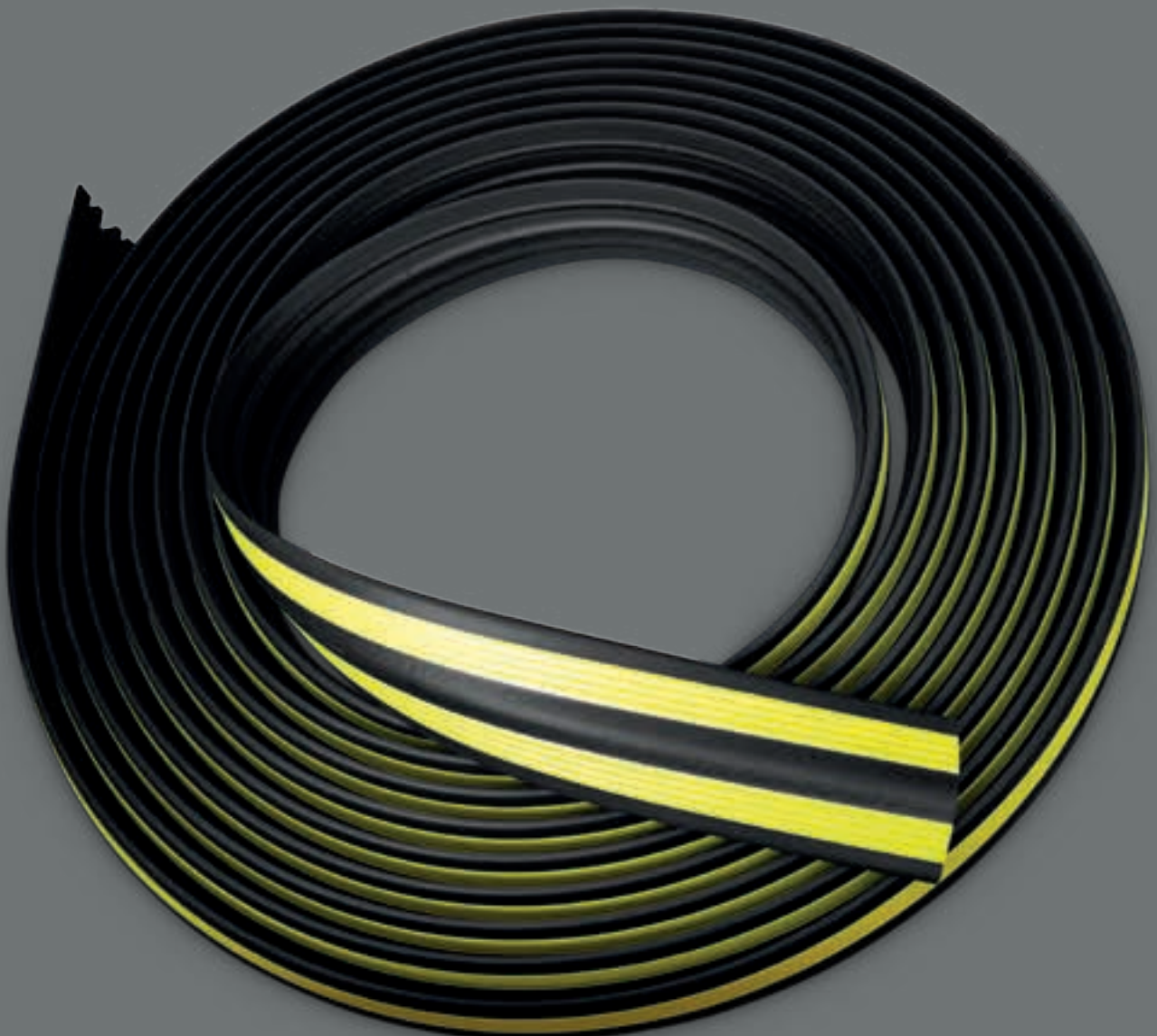

CABLE COVER

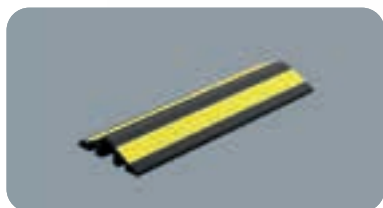
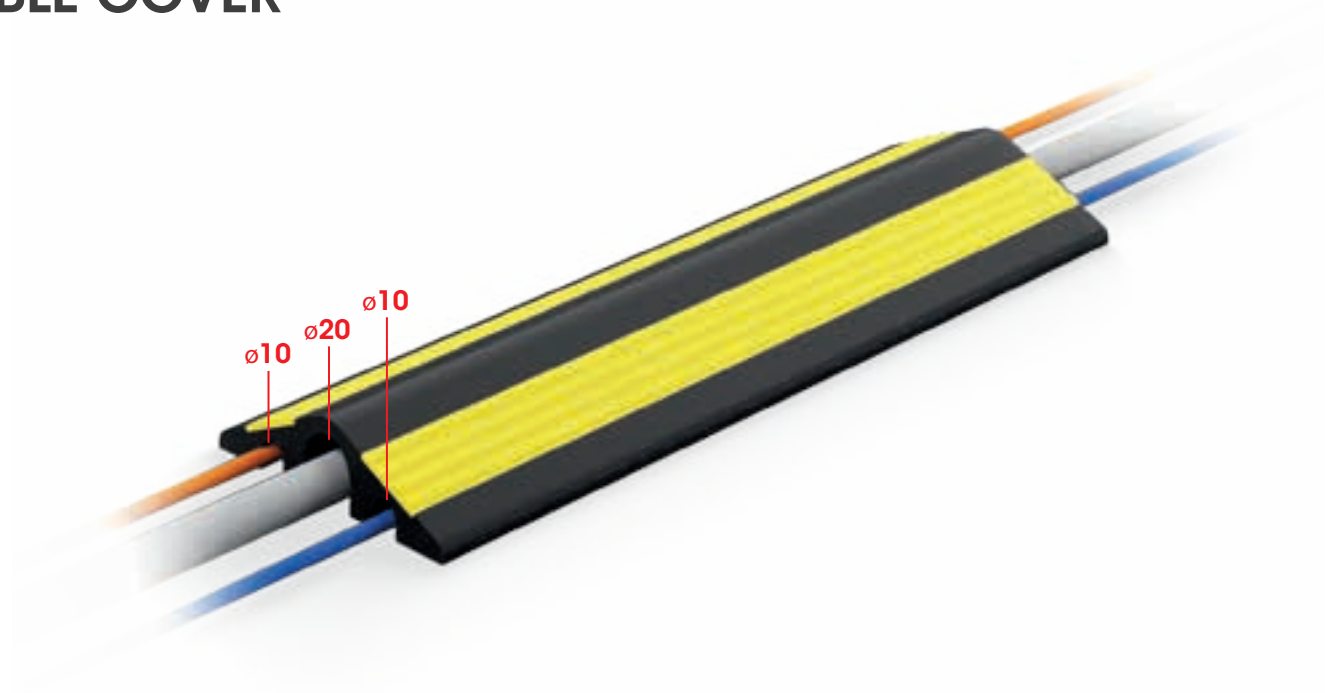

CAB CO 10 - 20 - 10

Recycled Material

Length 1.000 / 3.000 mm - 10.000 mm
Packing 8 pz / box - 1 pz / box

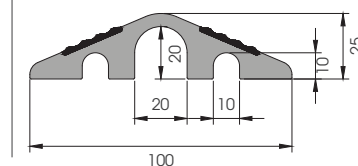

15

CORNER PROTECTION

Designed to protect pillars and columns or external corners of walls and panels.

Realizzato per proteggere pilastri e colonne o angoli esterni di muri e pannelli.

Étudié pour protéger les poteaux et les colonnes ou les angles extérieurs de murs et de panneaux.

Realizado para proteger pilares y columnas o esquinas exteriores de paredes y paneles.



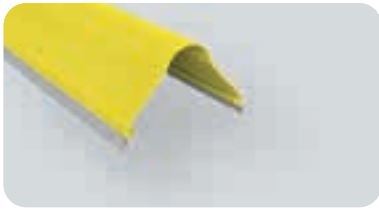

CP 100

Length **4.000 mm**
 Packing **10 pz / box**
 Colour **B M E F**

Length **2.000 mm**
 Packing **10 pz / bag**
 Colour **M**

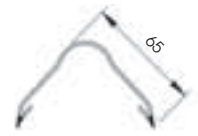

CPF 100

Length **4.000 mm**
 Packing **10 pz / bag**

Length **2.000 mm**
 Packing **10 pz / bag**



CPT 100

Packing **40 pz / box**
 Colour **B E F**

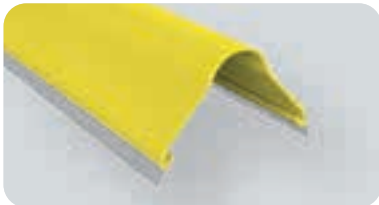

CP 200

Length **4.000 mm**
 Packing **2 pz / bag**
 Colour **B M E**

Length **2.000 mm**
 Packing **2 pz / bag**
 Colour **M**



CPF 200

Length **2.000 / 4.000 mm**
 Packing **2 pz / bag**



CPT 200

Packing **20 pz box**
 Colour **B E**

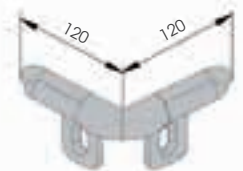

16

KERB PROTECTION

Large-sized protection system, ideal for walls and panels. Easy to install and clean. Fully equipped with corner caps and buttons.



Sistema di protezione di grandi dimensioni,
ideale per muri e pannelli. Facile da installare e pulire
Completo di angolari e tappi.

Système de protection
de grands dimensions, idéal
pour les murs et les panneaux.
Facile à installer et à nettoyer.
Complété de bouchons
d'angles et d'embouts.

Sistema de protección
de grande dimensión,
ideal para paredes
y paneles. Fácil de instalar
y limpiar. Completo de
esquinas y tapas.

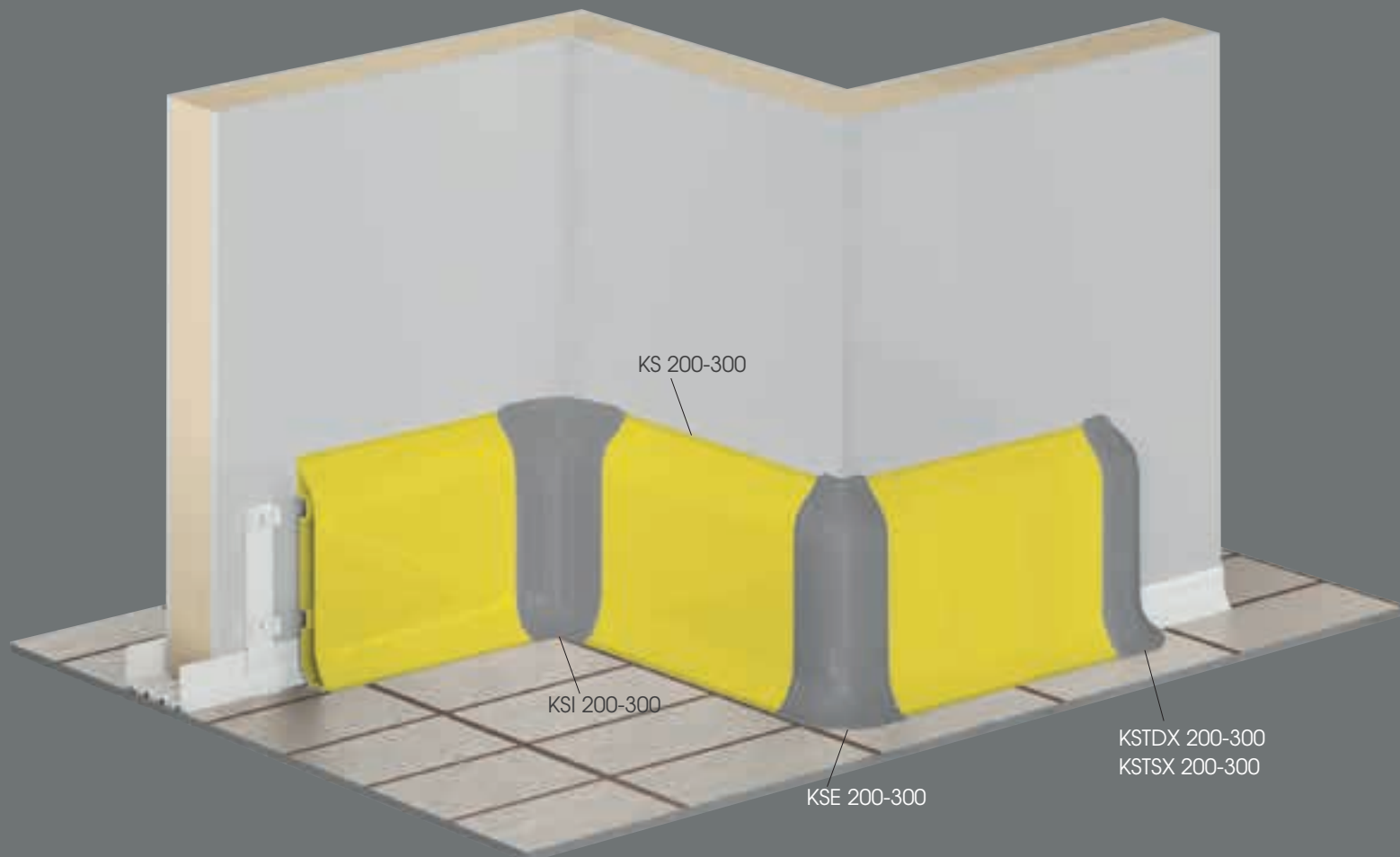

Kerb Protection



KS 200

Length **4.000 mm**
 Packing **3 pz / box**
 Colour **B M E**

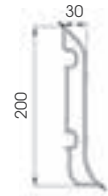

KEPF 200

Fixing to be defined

Packing **50 pz / box**
 Colour **K**

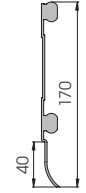

KSJ 200

To install with TB14 / TF14

Packing **20 pz / box**
 Colour **B E**

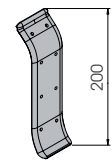

KSI 200

To install with TB14 / TF14

Packing **20 pz / box**
 Colour **B E**

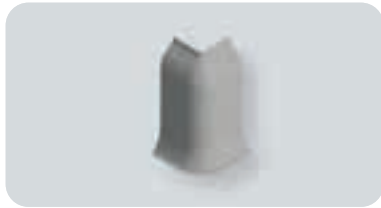
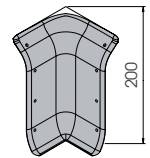

KSE 200

To install with TB14 / TF14

Packing **20 pz / box**
 Colour **B E**

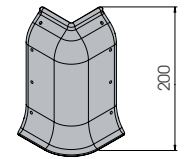

KSTDX/SX 200

To install with TB14 / TF14

Packing **20 pz / box**
 Colour **B E**

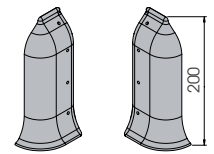

KSJ 200 LT



FLEXIBLE JOINT

Packing **to be defined**
 Colour **K**

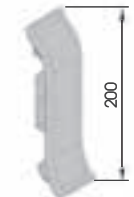

KS 300

Length **4.000 mm**
 Packing **1 pz**
 Colour **M E**

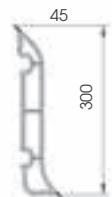

KEPF 300

Fixing to be defined

Packing **20 pz / box**

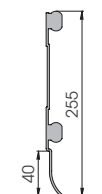



KSJ 300

To install with TB20 / TF20

Packing 10 pz / box

Colour B E

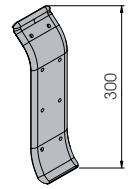

KSI 300

To install with TB20 / TF20

Packing 10 pz / box

Colour B E

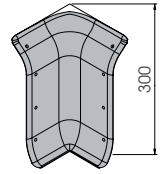

KSE 300

To install with TB20 / TF20

Packing 10 pz / box

Colour B E

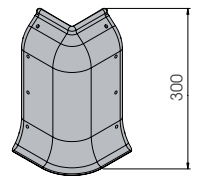

KSTD/SX 300

To install with TB20 / TF20

Packing 10 pz / box

Colour B E

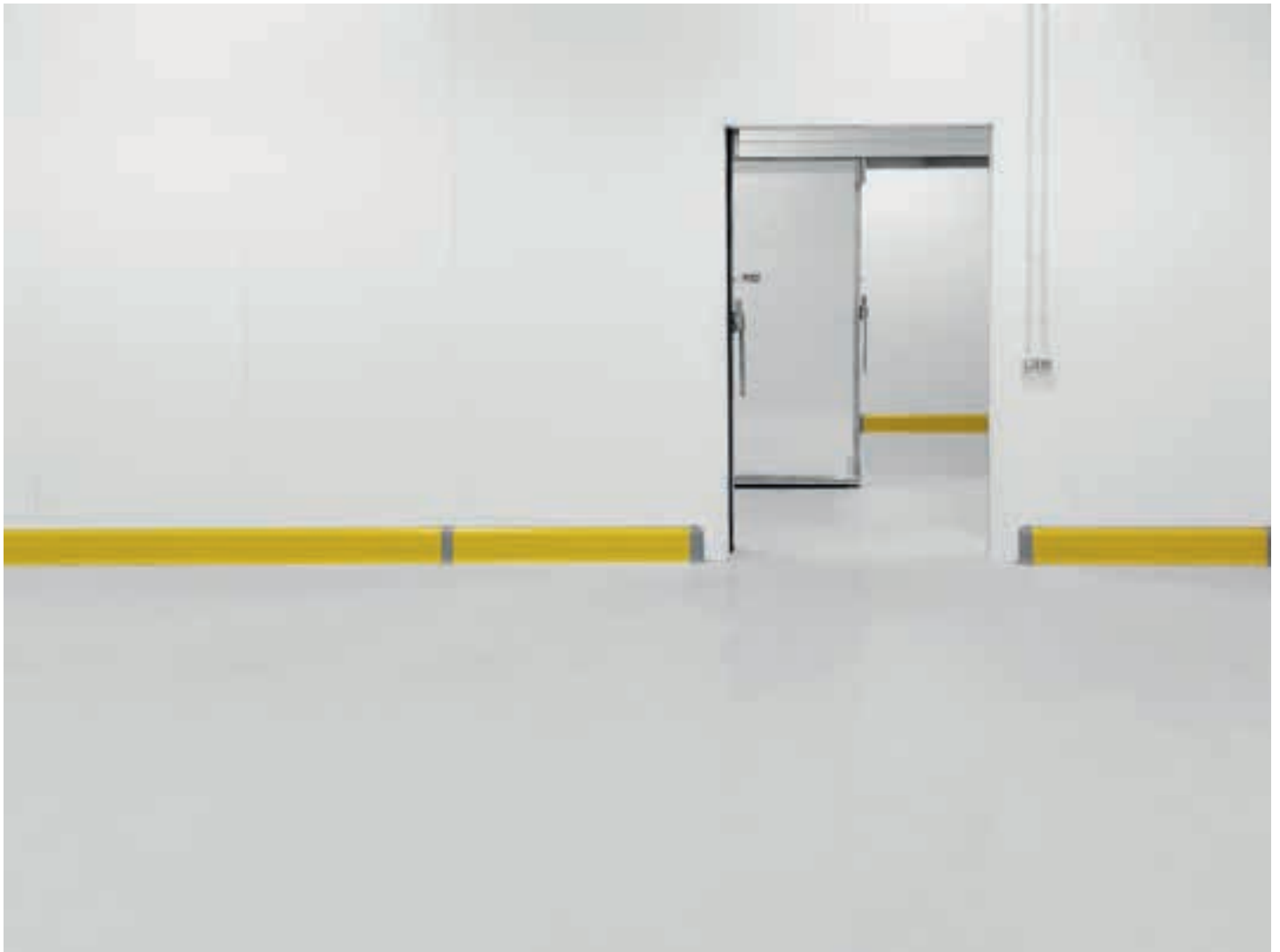
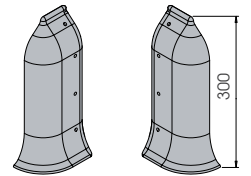

17

WALL PROTECTION

New bumper without guides. Thanks to its big size and resistance it is ideal for protection of industrial spaces. Fixed caps with hidden screws covered by specific buttons.

Nuovo profilo antiurto senza guida. La sua ampiezza e resistenza lo rende ideale per la protezione di ambienti industriali. Terminali fissati con viti nascoste da appositi bottoni.

Nouveau profilé anti-choc sans besoin d'une base à fixer. Sa mesure large et sa résistance en font le profilé parfait pour la protection des espaces industriels. Embouts fixés avec des vis cachées grâce à des bouchons spécifiques.

Nuevo perfil antigolpe sin guía. Su amplitud y resistencia lo hacen ideal para la protección de entornos industriales. Terminales fijados con tornillos ocultos por botones especiales.



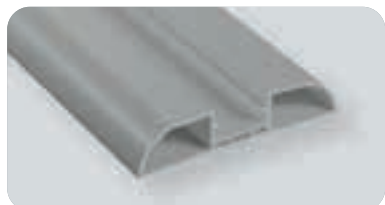

WP 100

Length **4.000 mm**
 Packing **8 pz / box**
 Colour **B E F**

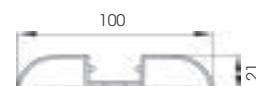

WP 150

Length **4.000 mm**
 Packing **4 pz / box**
 Colour **B M E**

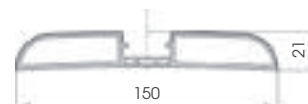

WPC

To install with WP 100 / WP 150

Length **4.000 mm**
 Packing **16 pz / box**
 Colour **A B M D E F G H**

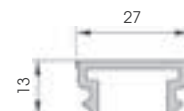

WPT 100

To install with TM5

Packing **50 pz / box**
 Colour **B E F**

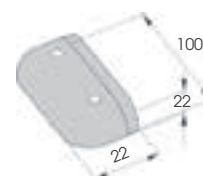

WPA 100

To install with TS9

Packing **20 pz / box**
 Colour **B E**



WPT 150

To install with TM5

Packing **50 pz / box**
 Colour **B E**

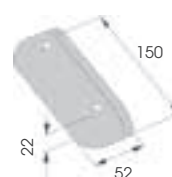

WPA 150

To install with TS9

Packing **20 pz / box**
 Colour **B E**



Wall Protection

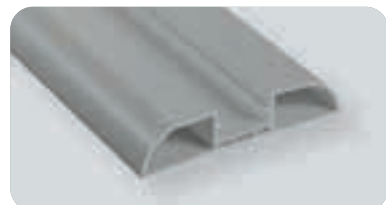
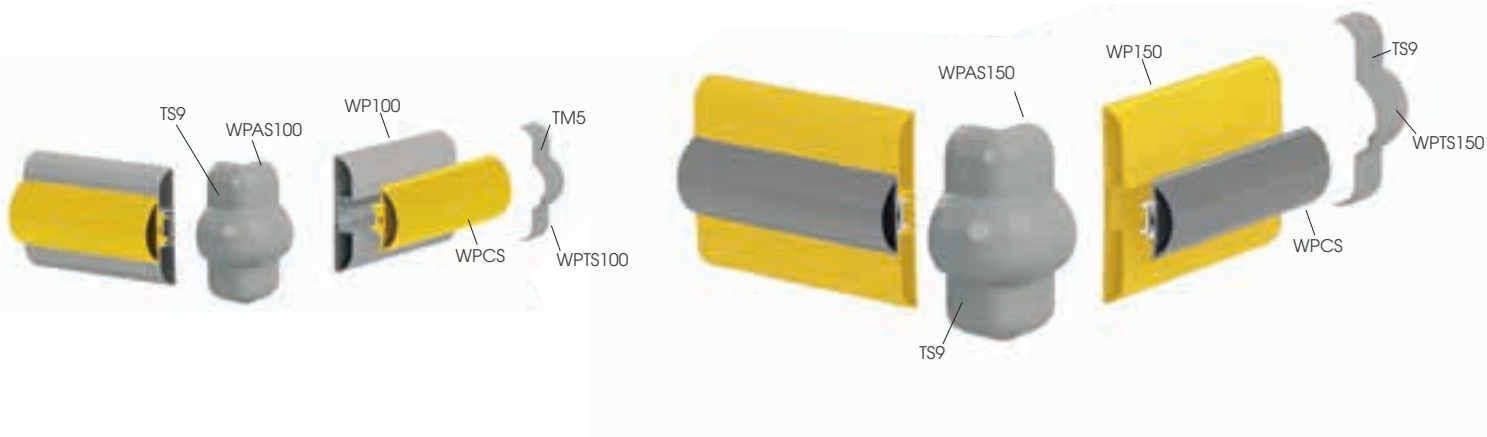

WP 100

Length **4.000 mm**
 Packing **8 pz / box**
 Colour **B E F**

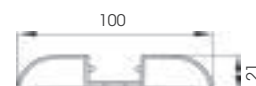

WP 150

Length **4.000 mm**
 Packing **4 pz / box**
 Colour **B M E**

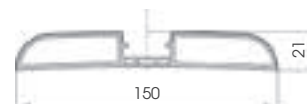

WPCS

To install with WP 100 / WP 150



Length **4.000 mm**
 Packing **8 pz / box**
 Colour **A B M D E F G H I**

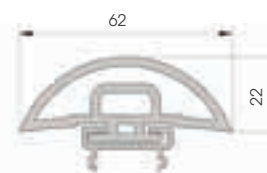

WPTS 100

To install with TS9

Packing **20 pz / box**
 Colour **B E**



WPAS 100

To install with TS9

Packing **20 pz / box**
 Colour **B E**

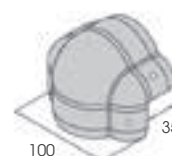

WPTS 150

To install with TS9

Packing **20 pz / box**
 Colour **B E**

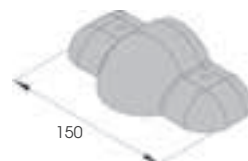

WPAS 150

To install with TS9

Packing **20 pz / box**
 Colour **B E**



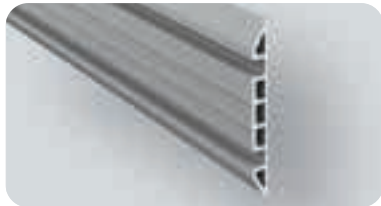
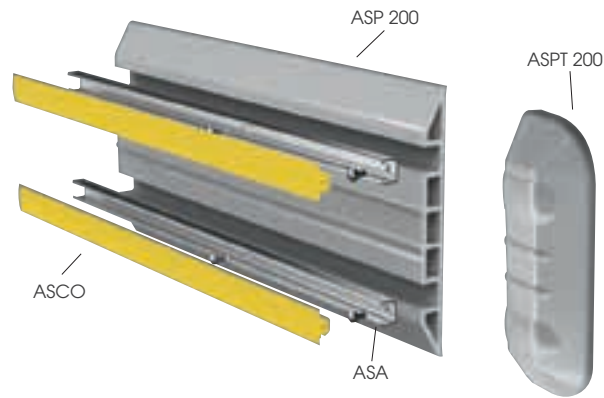

ASP 200



Length **4.000 mm**
 Packing **2 pz / box**
 Colour **B M**



ASPT 200



Packing **10 pz / box**
 Colour **B D**



ASA

Material **aluminium**
 Length **4.000 mm**
 Packing **8 pz / bundle**

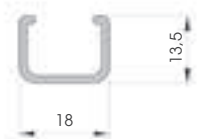

ASCO



Packing **2 pz / box**
L = 32.000 mm
 Colour **A B M D G**



Wall Protection



WALL HUG 1000
2000
3000
4000

Length 1000/2000/3000/4000
Packing unpacked
Colour M



WALL BFLEX 1000
2000
3000
4000

Length 1000/2000/3000/4000
Packing unpacked
Colour M

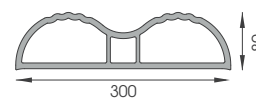

WALL BFLEX MODULAR

Packing unpacked
Colour M

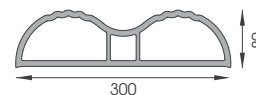



LOFT BARRIER

WORLD'S FIRST FIXED PROTECTION SYSTEM FOR SUSPENDED AREAS



FLEXI LINE

CORNER BUMPER GUARDS



FENCE LINK

STRONG ADAPTABLE SOLUTION FOR RACK-ENDS



Now available
CUSTOMISED RACK PROTECTOR,
new version of rack protector
processed upon request!

CUSTOMISED RACK PROTECTOR

Fixing accessories



M12 - M16

HILTI

Hole required \varnothing 12-16
Galvanized steel.



S12 - S12X150 - S16

HILTI

Hole required \varnothing 10-10-14
Galvanized steel.



B12 - B16 - B20

HILTI

Hole required \varnothing 22-28-32
Galvanized steel.



S8FH - S12FH

HILTI

Hole required \varnothing 6-10
Galvanized steel.
Countersunk.



SF12 - SF16 - SF20 INOX

Hole required \varnothing 14-18-24
Stainless steel.



M12 - M16 INOX

Hole required \varnothing 12-16
Stainless steel.



KIT ROD 70-120

HILTI

Hole required \varnothing 38-56
Galvanized steel.



KIT ROD 70-120 INOX

HILTI

Hole required \varnothing 38-56
Galvanized steel.



AA12 - AA16

Hole required \varnothing 22-22
Galvanized steel.
For asphalt.



ASPHALT CHEMICAL

CHEMICAL ANCHOR

385 ML



FR

HILTI CHEMICAL ANCHOR

300 ML



WIT NORDIC

CHEMICAL ANCHOR

420 ML

(Installation in working cold rooms
with negative temperatures)

In collaboration with



MPM srl reserves the right, at any time, to introduce the necessary changes and improvements to its products. Any small imperfection in the products and in the materials used are due to the processing method. Any reproduction of this brochure, even in part, is forbidden.



TM5
Hole required \varnothing 8.5
Neutral polyethylene. 100/500 Pcs. / bag.



TS9
Hole required \varnothing 5
White or grey nylon. 1000 Pcs. / bag.



TB14 - TB20
Hole required \varnothing 4-5
Steel / aluminium (white for \varnothing 4)
500 Pcs. / box.



TF14 - TF20
Hole required \varnothing 5-6.5
Aluminium. 500 Pcs. / box.



FIX P90
Galvanized steel and painted.



COVER 90 RE
Galvanized steel and painted.



FIX P90 INOX
Stainless steel.



FIX P150
Galvanized steel and painted.



COVER 150 RE
Galvanized steel and painted.



FIX P150 INOX
Stainless steel.



FIX P150 FH
Galvanized steel and painted.
Countersunk.



FULL FRAME BASE
Galvanized steel and painted.



SHOCK ABSORBER PAD
Soft material, optional for FIXP150.
(To be installed with S12x150)

Colours

A	B	D	E	F	G	H	I	K	L	M	P
RED RAL 3002	GREY RAL 7040	BLACK RAL 9005	WHITE RAL 9010	WHITE RAL 9002	BLUE RAL 5005	GREEN RAL 6029	SILVER RAL 9006	LIGHT GREY RAL 7035	DARK GREY RAL 7024	LIGHTYELLOW RAL 1018	ORANGE

MPM srl reserves the right, at any time, to introduce the necessary changes and improvements to its products. Any small imperfection in the products and in the materials used are due to the processing method. Any reproduction of this brochure, even in part, is forbidden.



**The leading supplier of permanent
Access and Safety Systems and
Components to the Construction and
Facility Management Industry.**



SOME OF OUR REFERENCES

DB SCHENKER



amazon®



Coca-Cola
Refreshments



FCA
FIAT CHRYSLER AUTOMOBILES



GARNIER

DSV
Global Transport and Logistics



SIEMENS



Colgate®



COMPLETED PROJECTS

FLEXIBLE PROTECTION

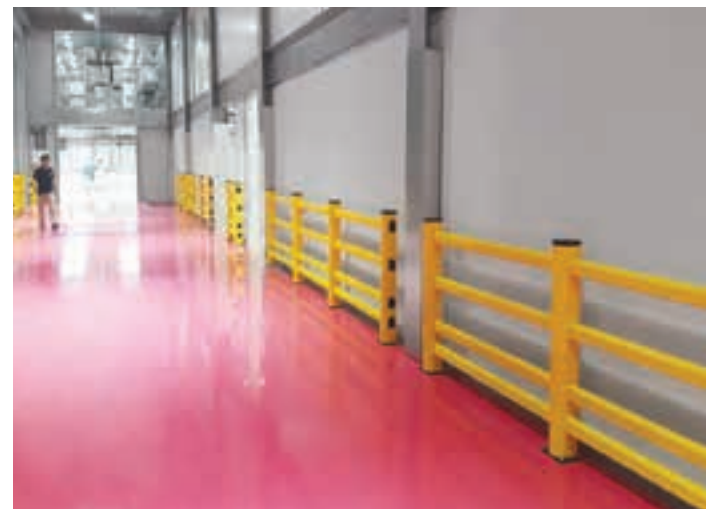

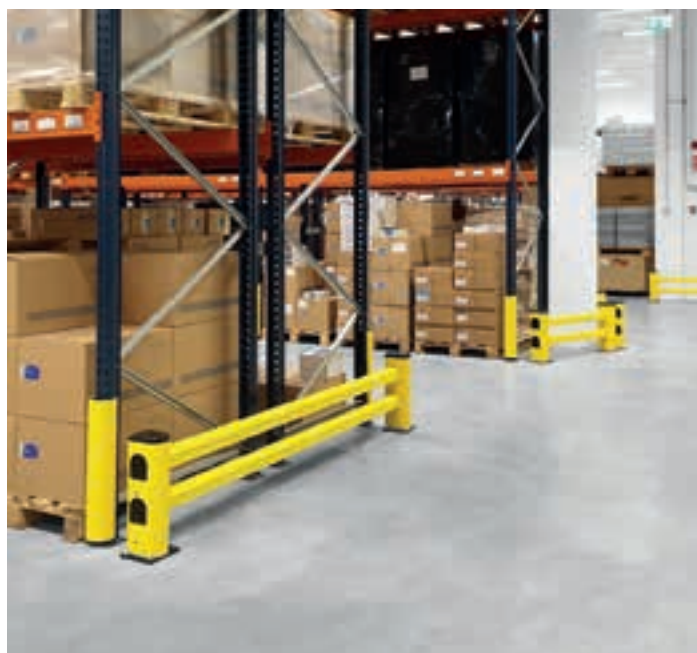

COMPLETED PROJECTS

FLEXIBLE PROTECTION





COMPLETED PROJECTS

FLEXIBLE PROTECTION

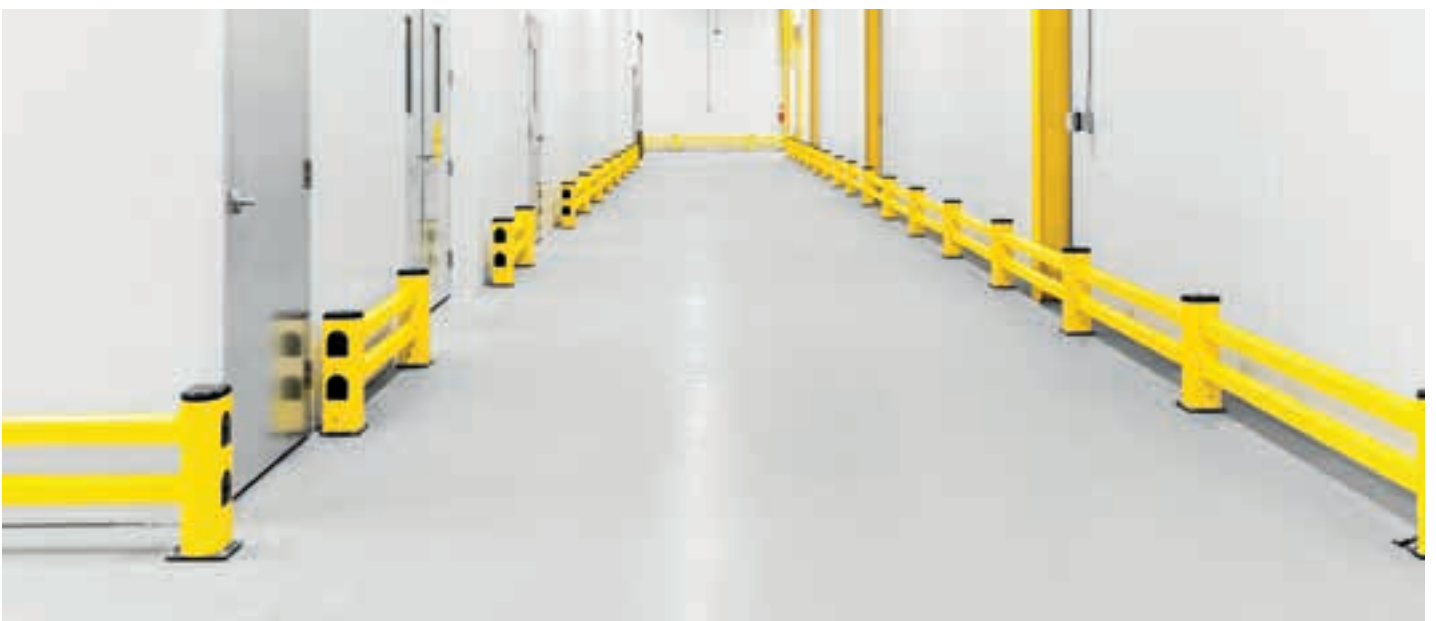

MPM states that:

The safety coefficient and consequent use of the products requires the compliance with the appropriate assembling and installation instructions as defined in the technical catalogue on the corporate website www.mpmprotections.com. Therefore, before buying and installing MPM solutions please consult the technical data sheet of each product in the technical catalogue available on www.mpmprotections.com

Impact resistances indicated in the brochure, or in other documents, refer to laboratory tests and cannot take into account consequences determined by installation methods or peculiarities of the place where the products are installed (in an operational environment vehicle type, speed and mass, routes, angles of impact, ground and anchorage are variable and uncontrolled conditions that no test can replicate); the data refers to an intact product which length is indicated on the test report and it can be affected by alterations from incorrect maintenance, wear and tear, as well as the methods and characteristics of installation (with specific reference to floor-mounted products); the weight, dimensions, colours and characteristics of the material refer to the sample and the conformity with the latter of the product supplied will be subject to normal production tolerance. The product may be affected by environmental installation conditions.

The standard operating temperature of MPM flexible protections is generally from +5 °C to +60 °C. For installations in low temperature environments up to -30 °C an alternative material should be required. The fastness of the colour and its brightness depend on wear and tear and weather conditions that can affect its intensity over time. For outdoor applications exposed to direct sunlight it is possible to choose the grey colour.

Images in the brochure are for advertising purposes only and do not in any way represent how the products should be used.

Full version of MPM products warranty available on corporate website www.mpmprotections.com



T. 0131 333 4413 E. SALES@KITEGROUPLTD.COM WWW.KITEGROUPLTD.COM

↗ Edinburgh office – 19 Bankhead Drive, Sighthill Industrial Estate, Edinburgh, EH11 4DW

↗ Sandbach office – Mosdec House, Moston Road, Sandbach, Cheshire CW11 3HL

