

TOWER LINK

COLUMN PROTECTION

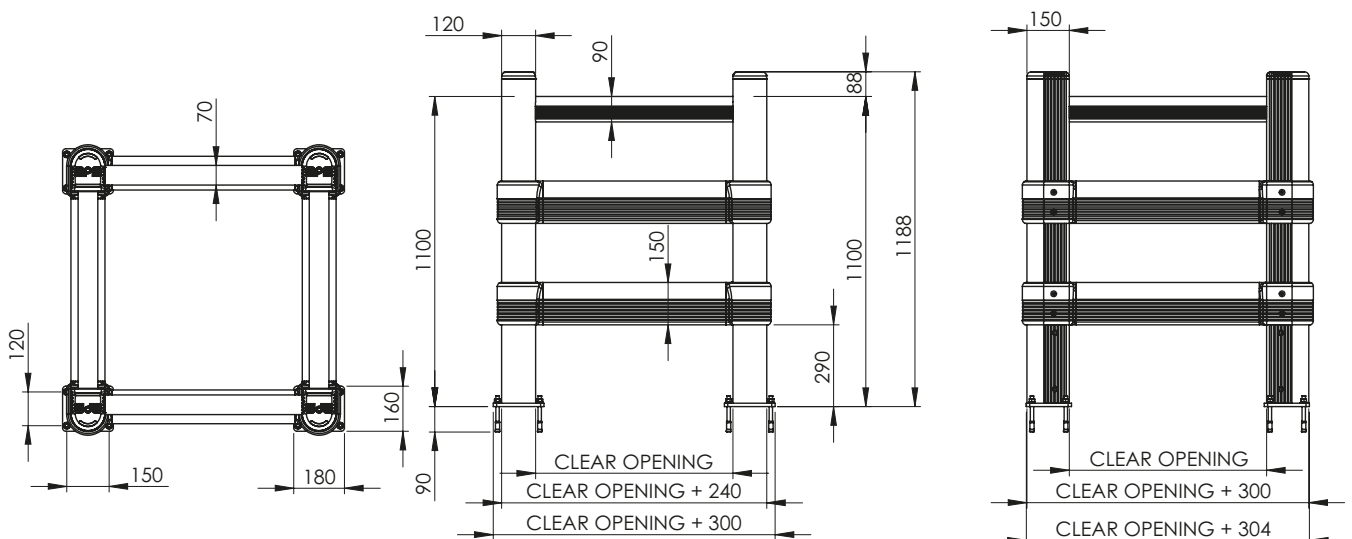
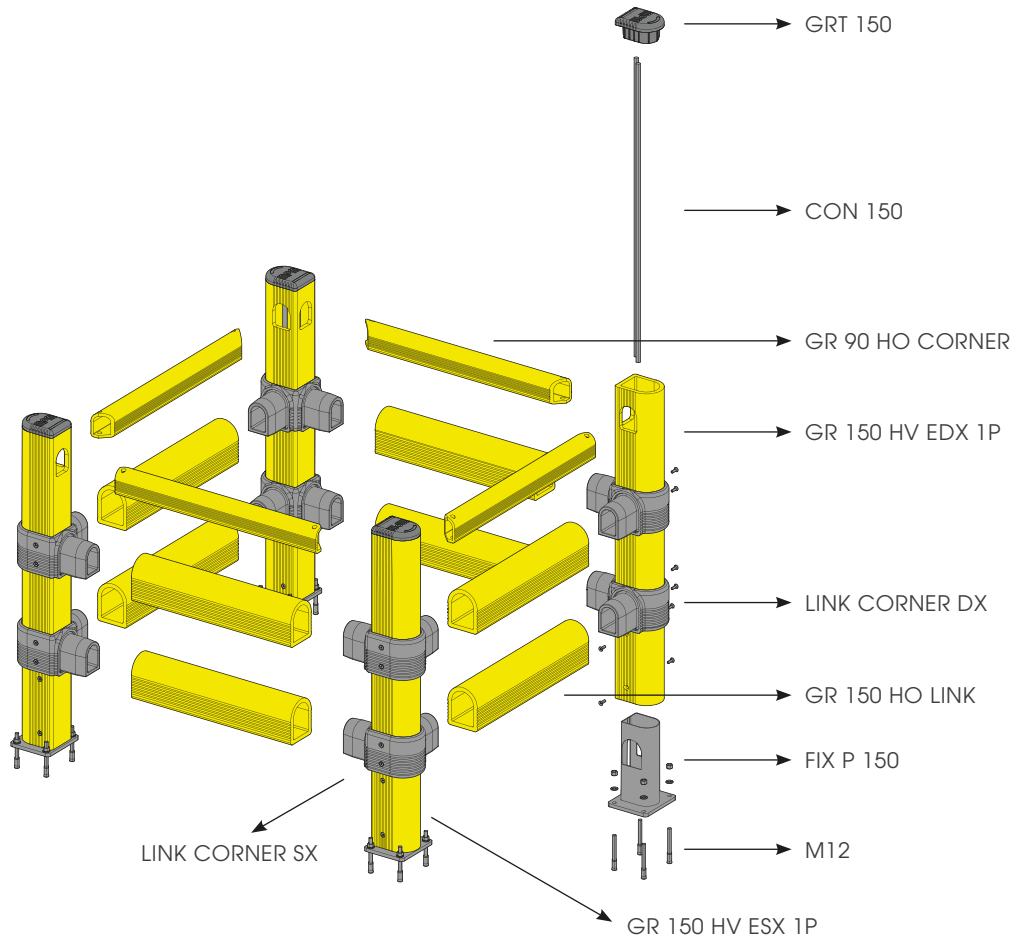

TOWER LINK

ASSEMBLY INSTRUCTIONS

SOLUTION DISPLAYED: **TOWER LINK/2**

Ø12 mm

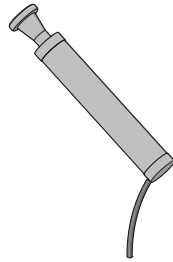

19

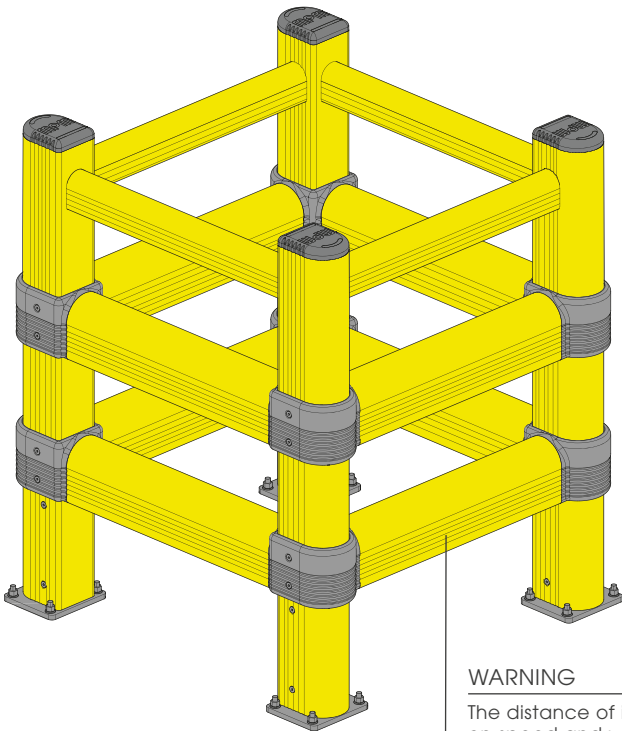
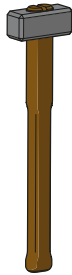
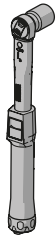

WARNING

The distance of installation depends on speed and weight of vehicle

COLUMN

MIN 100mm*

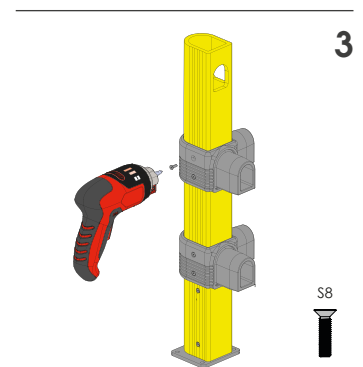
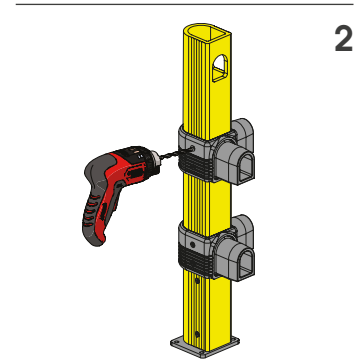
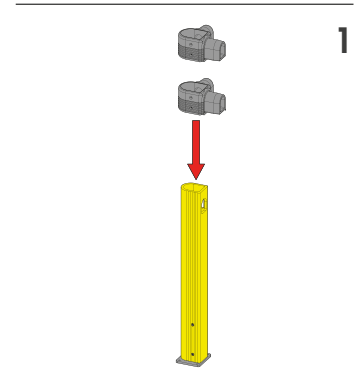

S8

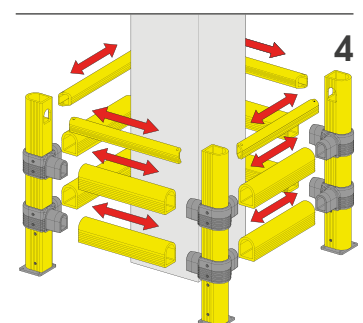

TOWER LINK

ASSEMBLY INSTRUCTIONS

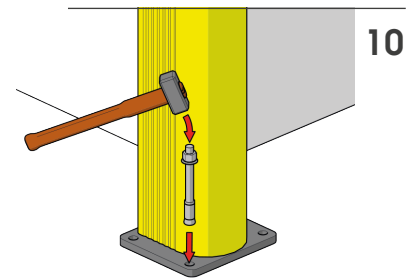
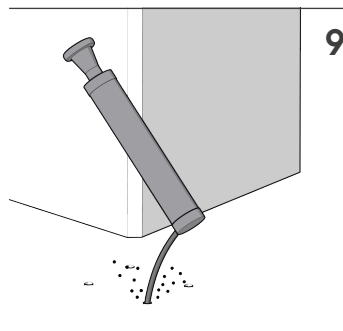
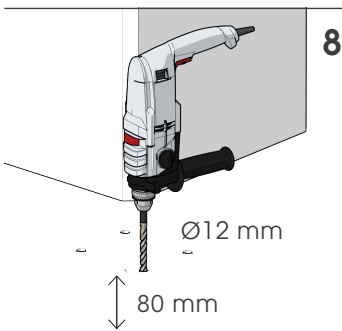
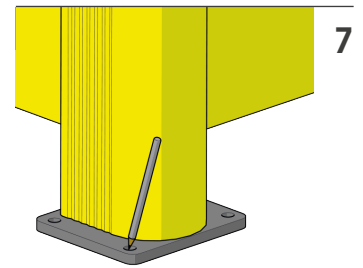
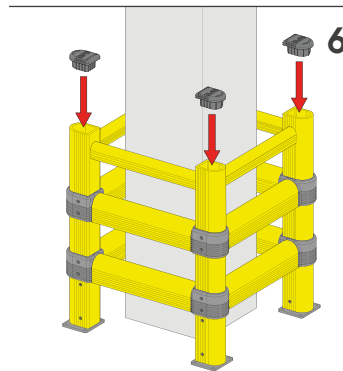
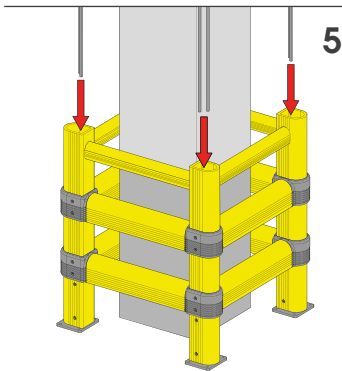

INSTALLATION TIP

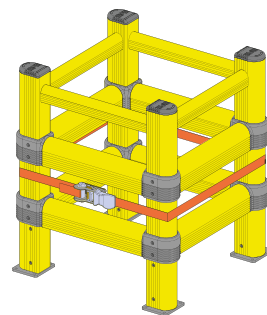
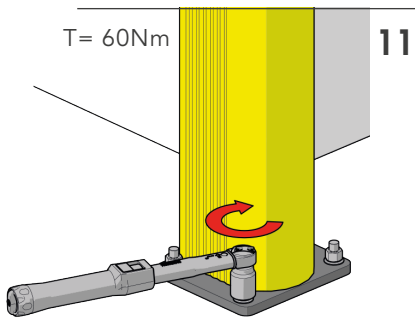

TOWER LINK/1

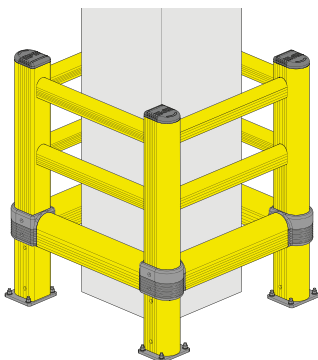

TOWER LINK/2

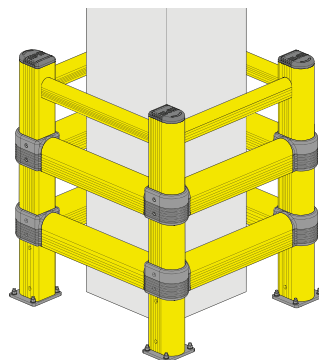

TOWER LINK/3

